

# Contura

Surround set

Ci8 Cosi

Surround set Ci8 Cosi .....	12
Surround set Ci8 Cosi Left / Right .....	42

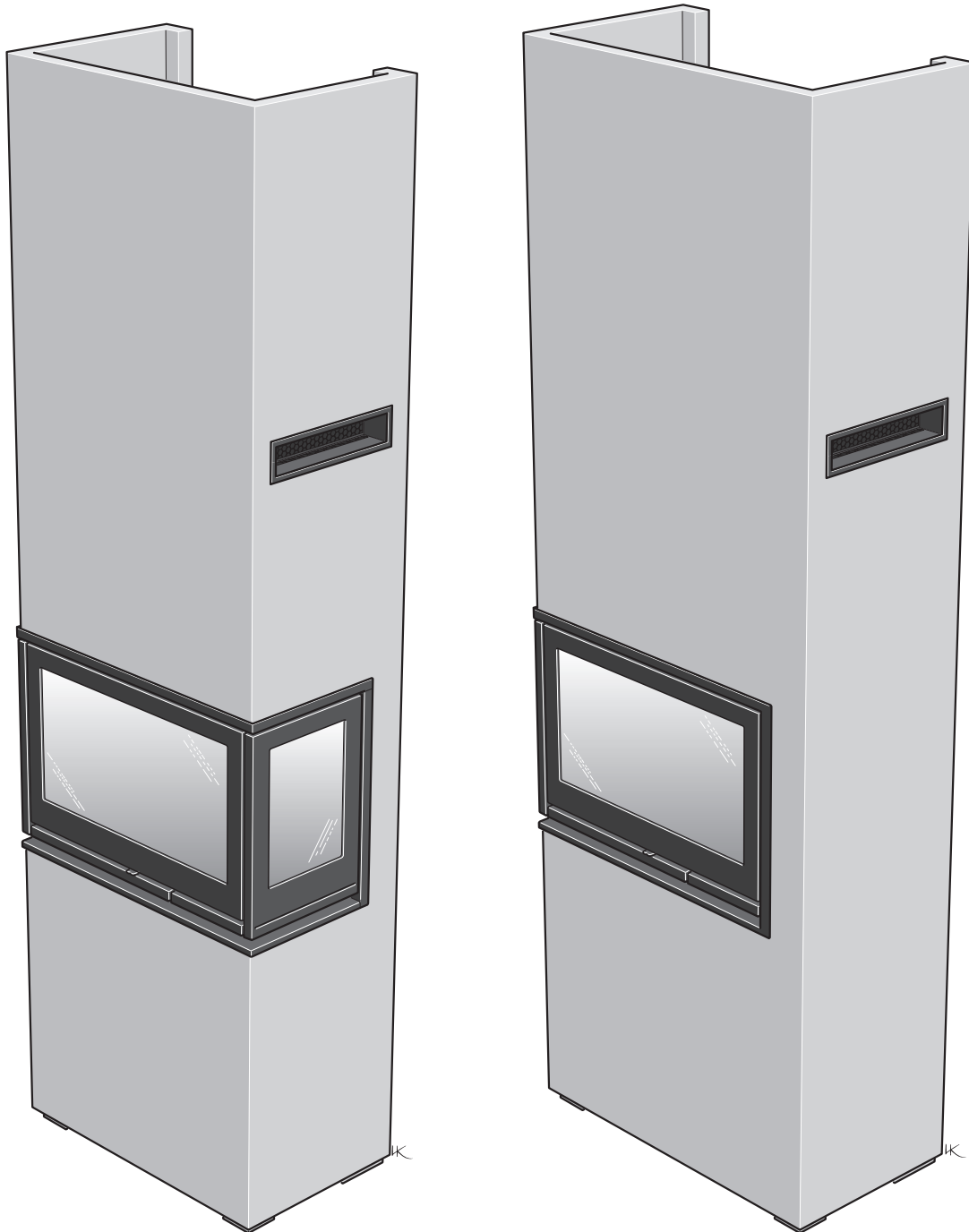



## Prestandadeklaration enligt förordning (EU) 305/2011

Nr. Ci8 Cosi-CPR-310521

# Contura

### PRODUKT

Typ	Vedeldad insats
Varunamn	Contura i8 Cosi
Avsedd användning	Rumsvärmare i bostadshus
Bränsle	Ved

### TILLVERKARE

Namn	NIBE AB / Contura
Adress	Box 134, Skulptörvägen 10 SE-285 23 Markaryd, Sverige

### VERIFIKATION

Enligt AVCP	System 3
Europastandard	EN 13229:2001/A2:2004/AC:2007
Testinstitut	Rein-Ruhr Feuerstätten Prüfstelle, NB 1625.

### DEKLARERAD PRESTANDA

VÄSENTLIGA EGENSKAPER	PRESTANDA	HARMONISERAD TEKNISK SPECIFIKATION
Brandsäkerhet	Klarar	EN 13229:2001 / A2:2004 / AC:2007
Brandteknisk klass	A1	
Minsta avstånd till brännbart material	Rygg: 100 mm (med brandskyddsskiva) Sida: 500 mm Tak: 20 mm Tak: 700 mm (frontgaller) Front: 1400 mm Golv: 0 mm	
Brandfara på grund av att brinnande bränsle faller ut	Klarar	
Rengörbarhet	Klarar	
Emissioner från förbränningen	CO: 0,08%	
Yttemperaturer	Klarar	
Temperatur på handtag	NPD	
Mekanisk hållfasthet	Klarar	
Temperatur i utrymme för vedförvaring	NPD	
Nominell effekt	7,0 kW	
Verkningsgrad	77,0%	
Rökgasttemperatur vid nominell effekt	324°C	
Rökgasttemperatur i anslutningsstos	389°C	

Undertecknad ansvarar för tillverkning och överensstämmelse med deklarerad prestanda.



**Niklas Gunnarsson**, Affärsområdeschef NIBE STOVES  
Markaryd den 31 maj 2021



## Leistungserklärung gemäß der Verordnung (EU) 305/2011

Nr. Ci8 Cosi-CPR-310521

# Contura

### PRODUKT

Typ	Holz befeuerten Einsatz
Typenbezeichnung	Contura i8 Cosi
Vorgesehener Verwendungszweck	Raumheizung in Wohngebäuden
Brennstoff	Holz

### HERSTELLER

Name	NIBE AB / Contura
Adresse	Box 134, Skulptörvägen 10 SE-285 23 Markaryd, Sverige

### VERIFIKATION

Gemäß AVCP	System 3
Europäische Norm	EN 13229:2001 / A2:2004 / AC:2007
Prüfstelle	Rein-Ruhr Feuerstätten Prüfstelle, NB 1625.

### DEKLARIERTE LESTUNG

WESENTLICHE EIGENSCHAFTEN	LEISTUNG	HARMONISIERTE TECHNISCHE SPEZIFIKATION
Brandsicherheit	Erfüllt	EN 13229:2001 / A2:2004 / AC:2007
Brandverhalten	A1	
Mindestabstand zu brennbarem Material	Hinten: 100 mm (mit Brandschutzscheibe) Seite: 500 mm Decke: 20 mm Decke: 700 mm (frontgitter) Front: 1400 mm Boden: 0 mm	
Brandgefahr durch Herausfallen von brennendem Brennstoff	Erfüllt	
Reinigbarkeit	Erfüllt	
Emission von Verbrennungsprodukten	CO: 0,08%	
Oberflächentemperatur	Erfüllt	
Temperatur auf dem Griff	NPD	
Mechanische Festigkeit	Erfüllt	
Temperatur i utrymme för vedförvaring	NPD	
Nennwärmeleistung	7,0 kW	
Wirkungsgrad	77,0%	
Abgastemperatur bei Nennwärmeleistung	324°C	
Abgastemperatur im Abgasstutzen	389°C	

Der Unterzeichner ist verantwortlich für die Herstellung und die Konformität mit der deklarierten Leistung.



**Niklas Gunnarsson**, Geschäftsbereichsleiter NIBE STOVES  
Markaryd 31. Mai 2021



## Ytelseserklæring i henhold til forordning (EU) 305/2011

Nr. Ci8 Cosi-CPR-310521

# Contura

### PRODUKT

Type	Vedfyrt innsats
Varenavn	Contura i8 Cosi
Beregnet bruksområde	Oppvarming av boliger
Brensel	Ved

### PRODUSENT

Navn	NIBE AB / Contura
Adresse	Box 134, Skulptörvägen 10 SE-285 23 Markaryd, Sverige

### KONTROLL

Ifølge AVCP	System 3
Europastandard	EN 13229:2001/A2:2004/AC:2007
Testinstitutt	Rein-Ruhr Feuerstätten Prüf stelle, NB 1625.

### ERKLÆRT YTELSE

VIKTIGE EGENSKAPER	YTELSE	HARMONISERT TEKNISK SPESIFIKASJON
Brannsikkerhet	Oppfyller	EN 13229:2001 / A2:2004 / AC:2007
Brannteknisk klasse	A1	
Minste avstand til brennbart materiale	Rygg: 100 mm (med brannbeskyttelsesplate) Side: 500 mm Tak: 20 mm Tak: 700 mm (frontgitter) Front: 1400 mm Gulv: 0 mm	
Brannfare på grunn av at brennende brensel faller ut	Oppfyller	
Rengjørbarhet	Oppfyller	
Utslipp fra forbrenningen	CO: 0,08 %	
Overflatetemperaturer	Oppfyller	
Temperatur på håndtak	NPD	
Bruddfasthet	Oppfyller	
Temperatur i oppbevaringsrommet for ved	NPD	
Nominell effekt	7,0 kW	
Virkningsgrad	77,0 %	
Røykgasstemperatur ved nominell effekt	324 °C	
Røykgasstemperatur i tilkoblingsstuss	389 °C	

Undertegnede har ansvar for produksjon og samsvar med erklært ytelse.



**Niklas Gunnarsson**, Forretningsområdesjef NIBE STOVES  
Markaryd 31. mai 2021



## Déclaration des performances conformément au Règlement (EU) 305/2011

N° Ci8 Cosi-CPR-310521

# Contura

### PRODUIT

Type Insert à combustibles solides  
 Nom commercial Contura i8 Cosi  
 Usage prévu du produit Chauffage des locaux dans les bâtiments résidentiels  
 Combustible Bois de chauffage

### FABRICANT

Nom NIBE AB / Contura  
 Adresse Box 134, Skulptörvägen 10  
 SE-285 23 Markaryd, Suède

### SYSTÈME D'ÉVALUATION ET DE VÉRIFICATION

Selon AVCP Système 3  
 Norme européenne EN 13229:2001/A2:2004/AC:2007  
 Organisme notifié Rein-Ruhr Feuerstätten Prüfstelle, NB 1625.

### PERFORMANCES DÉCLARÉES

CARACTÉRISTIQUES ESSENTIELLES	PERFORMANCES	SPÉCIFICATIONS TECHNIQUES HARMONISÉES
Sécurité incendie	Assure	EN 13229:2001 / A2:2004 / AC:2007
Réaction au feu	A1	
Distance minimale à respecter par rapport aux matériaux combustibles adjacents	Arrière : 100 mm (avec panneau coupe-feu) Côté : 500 mm Plafond : 20 mm Plafond : 700 mm (grille frontale) Face avant : 1400 mm Sol : 0 mm	
Risque de projections de braises	Assure	
Possibilités de nettoyage	Assure	
Émissions provenant de la combustion	CO : 0,08 %	
Températures de surface	Assure	
Température de la poignée	NPD	
Résistance mécanique	Assure	
Température dans l'espace pour le stockage du bois	NPD	
Puissance nominale	7,0 kW	
Rendement	77,0 %	
Température des fumées à la puissance nominale	324 °C	
Température des fumées dans le conduit de raccordement en fonctionnement nominal	389 °C	

Le soussigné est seul responsable de la fabrication et de la conformité des performances déclarées.



**Niklas Gunnarsson**, Responsable de division NIBE STOVES  
 Markaryd. 31 mai 2021



## Declaration of performance according to Regulation (EU) 305/2011

No. Ci8 Cosi-CPR-310521

# Contura

### PRODUCT

Type Wood burning insert  
Trade name Contura i8 Cosi  
Intended area of use Heating of rooms in residential buildings  
Fuel Wood

### MANUFACTURER

Name NIBE AB / Contura  
Address Box 134, Skulptörvägen 10  
SE-285 23 Markaryd, Sweden

### VERIFICATION

According to AVCP System 3  
European standard EN 13229:2001 / A2:2004 / AC:2007  
Test institute Rein-Ruhr Feuerstätten Prüfstelle, NB 1625.

### DECLARED PERFORMANCE

ESSENTIAL CHARACTERISTICS	PERFORMANCE	HARMONISED TECHNICAL SPECIFICATION
Fire safety	Pass	EN 13229:2001 / A2:2004 / AC:2007
Fire classification	A1	
Minimum distance to flammable materials	Rear: 100 mm (with heat shield) Side: 500 mm Ceiling: 20 mm Ceiling: 700 mm (front grate) Front: 1400 mm Floor: 0 mm	
Fire hazard due to burning fuel falling out	Pass	
Cleanability	Pass	
Emissions from combustion	CO: 0,08%	
Surface temperatures	Pass	
Temperature on the handle	NPD	
Mechanical resistance	Pass	
Temperature in the space for wood storage	NPD	
Nominal output	7,0 kW	
Efficiency	77,0%	
Flue gas temperature at nominal output	324°C	
Flue gas temperature in flue spigot	389°C	

The undersigned is responsible for the manufacture and conformity with the declared performance.



**Niklas Gunnarsson**, Business area manager NIBE STOVES  
Markaryd May 31, 2021



## Ydeevnedeklaration i henhold til forordning (EU) 305/2011

Nr. Ci8 Cosi-CPR-310521

# Contura

### PRODUKT

Type	Indsats fyret med fast brændsel
Varenavn	Contura i8 Cosi
Tiltænkt anvendelse	Rumopvarmning i boliger
Brændsel	Brænde

### PRODUCENT

Navn	NIBE AB / Contura
Adresse	Box 134, Skulptörvägen 10 SE-285 23 Markaryd, Sverige

### KONTROL

I henhold til AVCP	System 3
Europæisk standard	EN 13229:2001/A2:2004/AC:2007
Testinstitut	Rein-Ruhr Feuerstätten Prüf stelle, NB 1625.

### DEKLARERET YDEEVNE

VÆSENTLIGE EGENSKABER	YDEEVNE	HARMONISERET TEKNISK SPECIFIKATION
Brandsikkerhed	Bestået	EN 13229:2001 / A2:2004 / AC:2007
Brandteknisk klasse	A1	
Mindste afstand til brændbart materiale	Bagside: 100 mm (med brandbeskyttelsesplade) Side: 500 mm Loft: 20 mm Loft: 700 mm (frontgitter) Front: 1400 mm Gulv: 0 mm	
Risiko for at gløder falder ud	Bestået	
Rengøringsvenlighed	Bestået	
Emissioner fra forbrændingen	CO: 0,08 %	
Overfladetemperaturer	Bestået	
Håndtagstemperatur	NPD	
Mekanisk styrke	Bestået	
Temperatur i rum til opbevaring af brænde	NPD	
Nominel effekt	7,0 kW	
Virkningsgrad	77,0 %	
Røggastemperatur ved nominel effekt	324 °C	
Røggastemperatur i tilslutningsstuds	389 °C	

Undertegnede bærer ansvaret for fremstilling og overensstemmelse med deklareret ydeevne.



**Niklas Gunnarsson**, Forretningsområdechef for NIBE STOVES  
Markaryd 31. maj 2021





## Suoritusasoilmoitus asetuksen (EU) 305/2011 mukaan

Nr. Ci8 Cosi-CPR-310521

# Contura

### TUOTE

Tyyppi	Puulämmitteinen takkasydän
Tuotenimi	Contura i8 Cosi
Käyttötarkoitus	Asuintilojen lämmitys
Polttoaine	Puu

### VALMISTAJA

Nimi	NIBE AB / Contura
Osoite	Box 134, Skulptörvägen 10 SE-285 23 Markaryd, Ruotsi

### SERTIFIointi

AVCP-menettely	Järjestelmä 3
Eurostandardi	EN 13229:2001 / A2:2004 / AC:2007
Ilmoitettu elin	Rein-Ruhr Feuerstätten Prüf stelle, NB 1625.

### ILMOITETTU SUORITUSTASO

PERUSOMINAISUUDET	SUORITUSTASO	YHDENMUKAISTETUT TEKNISET ERITELMÄT
Palonkestävyys	Hyväksytty	EN 13229:2001 / A2:2004 / AC:2007
Palotekninen luokka	A1	
Suojaetäisyys palavaan materiaaliin	Takapuoli: 100 mm (palosuojalevyn kanssa) Sivu: 500 mm Katto: 20 mm Katto: 700 mm (etusäleikkö) Etupuoli: 1400 mm Lattia: 0 mm	
Palovaara ulos putoavan palavan polttoaineen vuoksi	Hyväksytty	
Puhdistettavuus	Hyväksytty	
Palamispäästöt	CO: 0,08%	
Pintalämpötilat	Hyväksytty	
Kahvan lämpötila	NPD	
Mekaaninen lujuus	Hyväksytty	
Polttopuiden säilytystilan lämpötila	NPD	
Nimellisteho	7,0 kW	
Hyötysuhde	77,0%	
Savukaasujen lämpötila nimellisteholla	324°C	
Savukaasujen enimmäislämpötila	389°C	

Allekirjoittanut vastaa tuotannosta ja ilmoitetun suoritusason noudattamisesta.



**Niklas Gunnarsson**, Liiketoimintoalueen päällikkö NIBE STOVES  
Markaryd 31. toukokuuta 2021



## Dichiarazione di prestazione conformemente al regolamento (UE) 305/2011

N. Ci8 Così-CPR-310521

# Contura

### PRODOTTO

Tipo Caminetto alimentato a legna  
 Nome commerciale Contura i8 Così  
 Uso previsto Riscaldamento per abitazioni private  
 Combustibile Legna

### PRODUTTORE

Nome NIBE AB / Contura  
 Indirizzo Box 134, Skulptörvägen 10  
 SE-285 23 Markaryd, Svezia

### VERIFICA

Conforme a AVCP Sistema 3  
 Standard europei EN 13229:2001/A2:2004/AC:2007  
 Ente notificato Rein-Ruhr Feuerstätten Prüfstelle, NB 1625.

### PRESTAZIONI DICHIARATE

CARATTERISTICHE FONDAMENTALI	PRESTAZIONI	SPECIFICHE TECNICHE ARMONIZZATE
Sicurezza antincendio	Conforme	EN 13229:2001 / A2:2004 / AC:2007
Classe di resistenza al fuoco	A1	
Distanza minima da materiale infiammabile	Retro: 100 mm (con piastra ignifuga) Lato: 500 mm Soffitto: 20 mm Soffitto: 700 mm (Griglia frontale) Fronte: 1400 mm Pavimento: 0 mm	
Rischio di incendio dovuto alla caduta di combustibile	Conforme	
Pulizia	Conforme	
Emissioni prodotte dalla combustione	CO: 0,08%	
Temperatura superficiale	Conforme	
Temperatura della maniglia	NPD	
Resistenza meccanica	Conforme	
Temperatura del vano di stoccaggio legna	NPD	
Potenza nominale	7,0 kW	
Rendimento	77,0%	
Temperatura dei fumi con potenza nominale	324°C	
Temperatura dei fumi nel raccordo	389°C	

Il sottoscritto è responsabile della produzione e della conformità alle prestazioni qui dichiarate.



**Niklas Gunnarsson**, Responsabile NIBE STOVES  
 Markaryd 31 maggio 2021



## Prestatieverklaring conform verordening (EU) 305/2011

Nr. Ci8 Cosi-CPR-310521

# Contura

### PRODUCT

Producttype	Houtgestookte inzet
Typeaanduiding	Contura i8 Cosi
Beoogd gebruik	Ruimteverwarmer in woning
Brandstof	Hout

### FABRIKANT

Naam	NIBE AB / Contura
Adres	Box 134, Skulptörvägen 10 SE-285 23 Markaryd, Zweden

### KEURING

Conform AVCP	Systeem 3
Europese standaard	EN 13229:2001/A2:2004/AC:2007
Testinstituut	Rein-Ruhr Feuerstätten Prüfstelle, NB 1625.

### GENOEMDE PRESTATIES

BELANGRIJKE EIGENSCHAPPEN	PRESTATIES	GEHARMONISEERDE TECHNISCHE SPECIFICATIE
Brandveiligheid	Goedgekeurd	EN 13229:2001 / A2:2004 / AC:2007
Brandtechnische klasse	A1	
Minimale afstand tot brandbare materialen	Achterkant: 100 mm (met brandveilige plaat) Zijkant: 500 mm Plafond: 20 mm Plafond: 700 mm (rooster voorzijde) Voorzijde: 1400 mm Vloer: 0 mm	
Brandbaarheid vanwege uitvallende gloeiende brandstoffen	Goedgekeurd	
Reinigbaarheid	Goedgekeurd	
Emissies van verbranding	CO: 0,08%	
Oppervlaktetemperaturen	Goedgekeurd	
Temperatuur handgreep	NPD	
Mechanische duurzaamheid	Goedgekeurd	
Temperatuur in houtvak	NPD	
Nominaal vermogen	7,0 kW	
Rendement	77,0%	
Rookgastemperatuur bij nominaal vermogen	324°C	
Rookgastemperatuur in het aansluitstuk	389°C	

Ondergetekende is verantwoordelijk voor de productie en overeenstemming met de genoemde prestaties.



**Niklas Gunnarsson**, Hoofd Business Area NIBE STOVES  
Markaryd 31 mei 2021



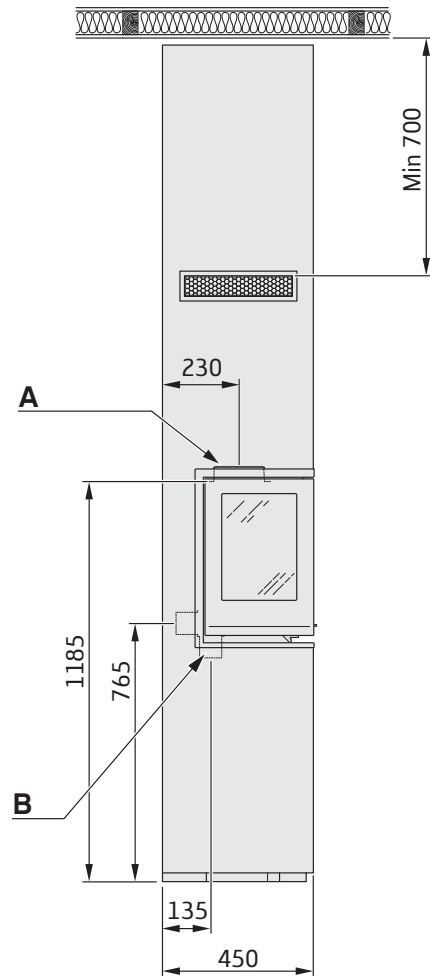
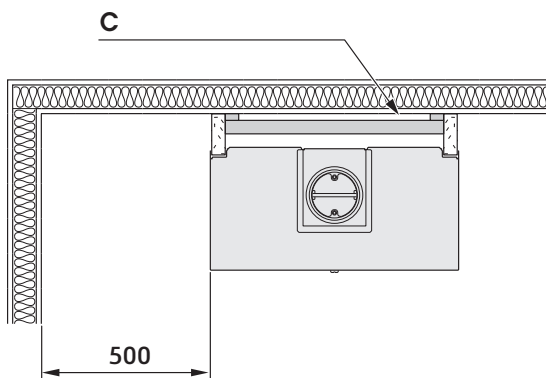
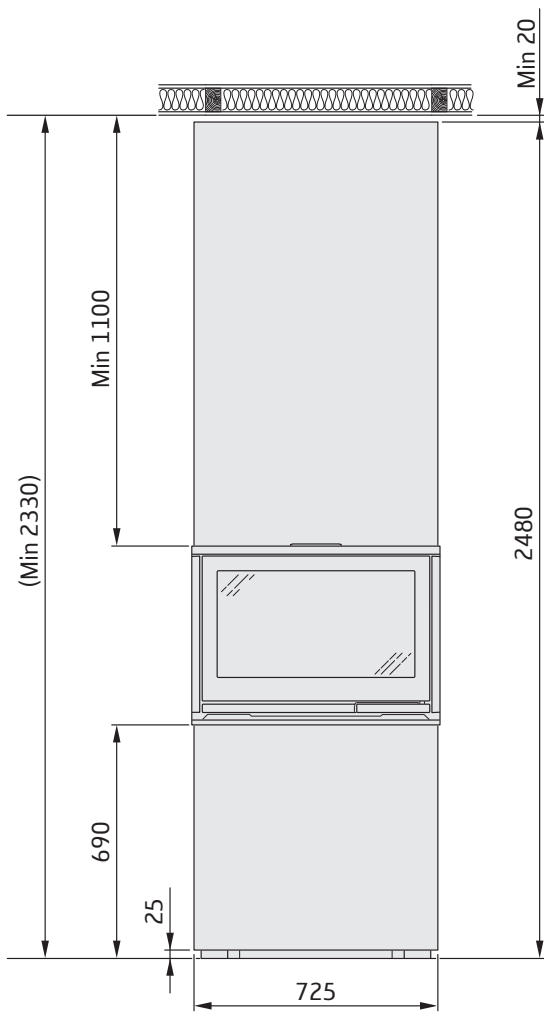

- SE** A. Utv. Ø150 mm  
B. Tilluftsstos Ø65 mm  
C. 20 mm Luftspalt
- DE** A. Außengew. Ø150 mm  
B. Zuluftstutzen Ø65 mm  
C. 20 mm Luftspalt
- NO** A. Utv. Ø150 mm  
B. Tilkobling til forbrenningsluft Ø65 mm  
C. 20 mm Luftspalte
- FR** A. Diam. ext. Ø150 mm  
B. Manchon d'arrivée d'air Ø65 mm  
C. 20 mm lame d'air
- GB** A. Ext. Ø150 mm  
B. Air inlet Ø65 mm  
C. 20 mm Air gap
- DK** A. Udv. Ø150 mm  
B. Friskluftsstuds Ø65 mm  
C. 20 mm Luftspalte
- FI** A. Ulkop. Ø150 mm  
B. Palamisilmaliitäntä Ø65 mm  
C. 20 mm Ilmarako
- IT** A. Esterno Ø150 mm  
B. Bocchetta di presa d'aria esterna Ø65 mm  
C. 20 mm di spazio libero
- NL** A. Buitendiam. Ø150 mm  
B. Toevoerluchtaansluiting Ø65 mm  
C. 20 mm Luchtspleet



175 kg

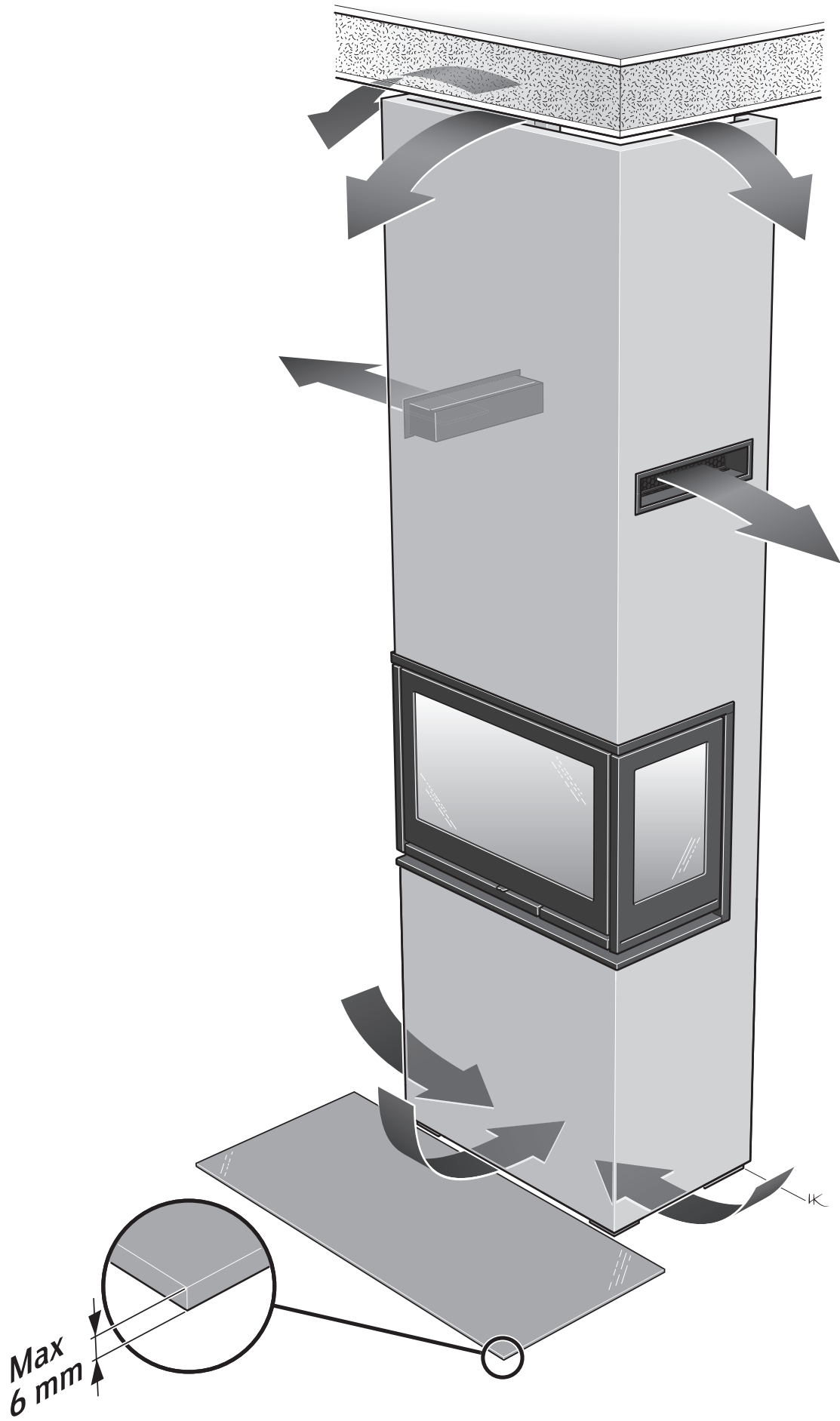

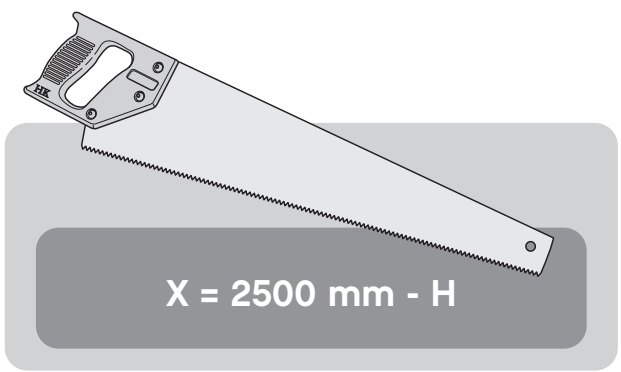
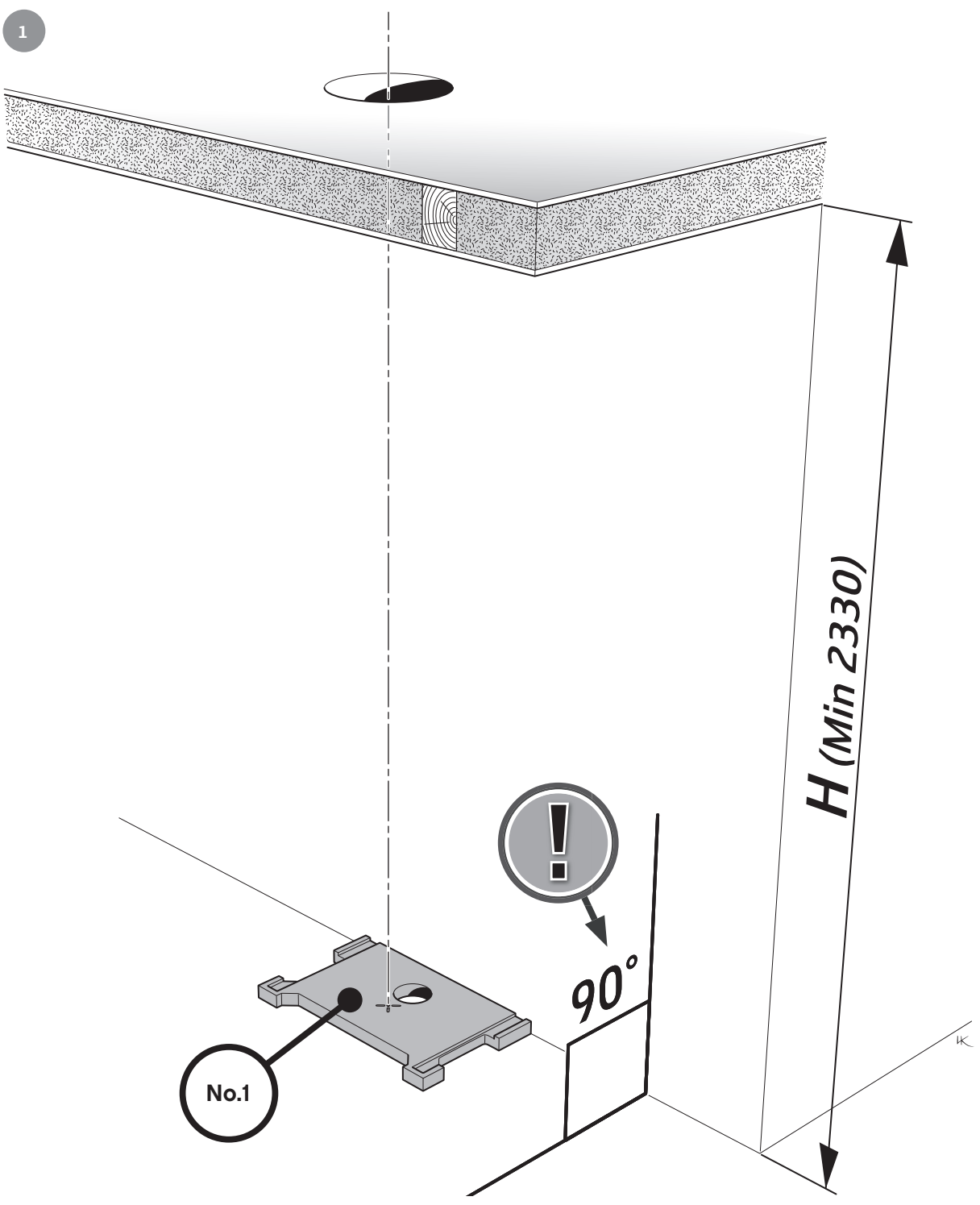

X = 2500 mm - H



2

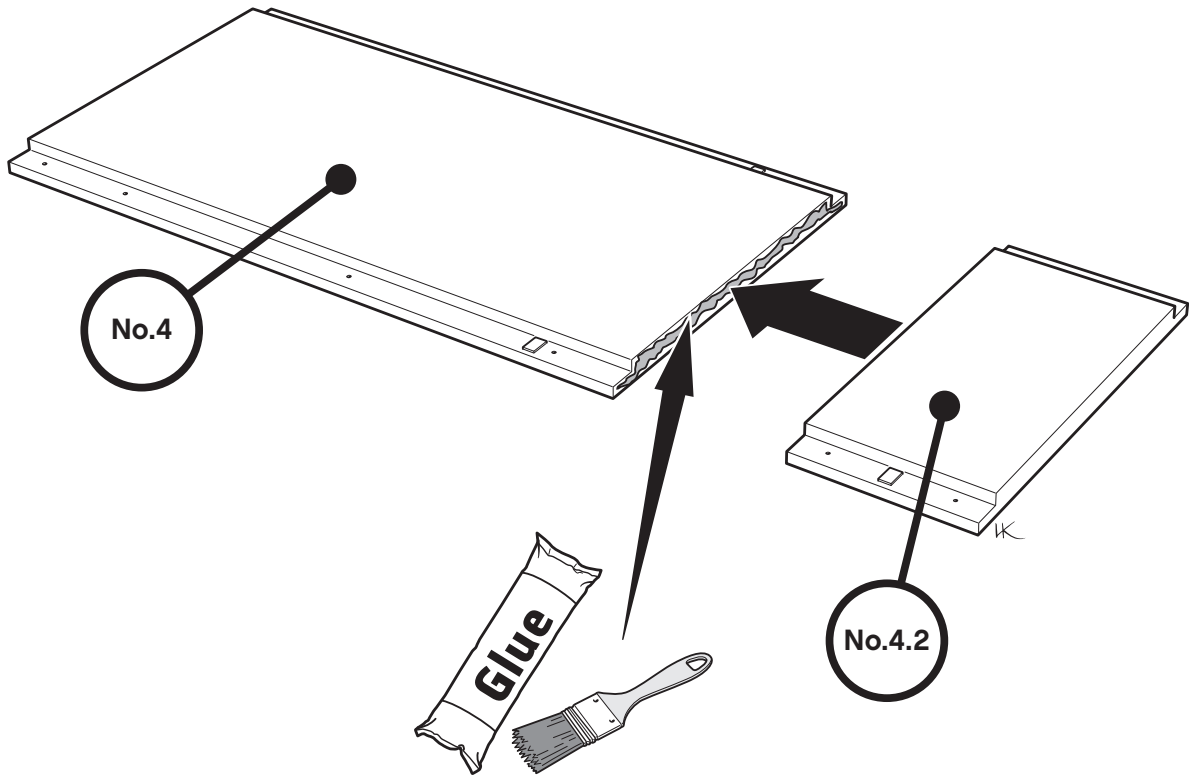

3

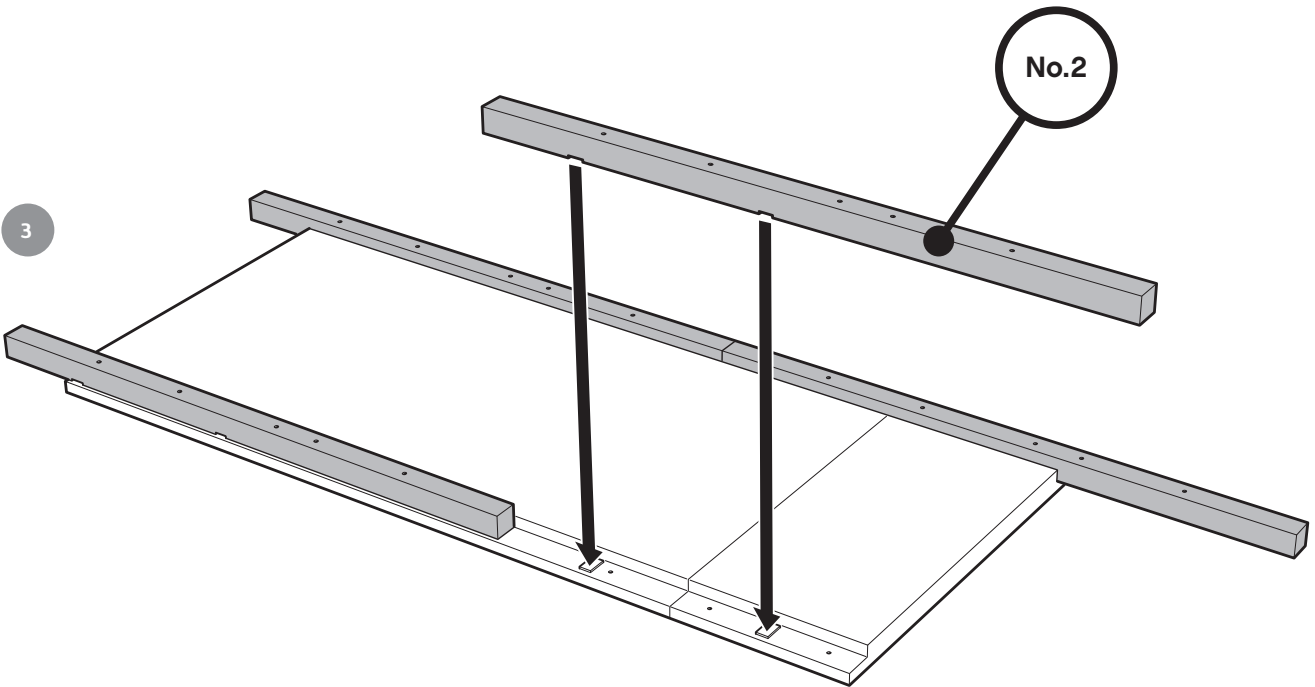



4

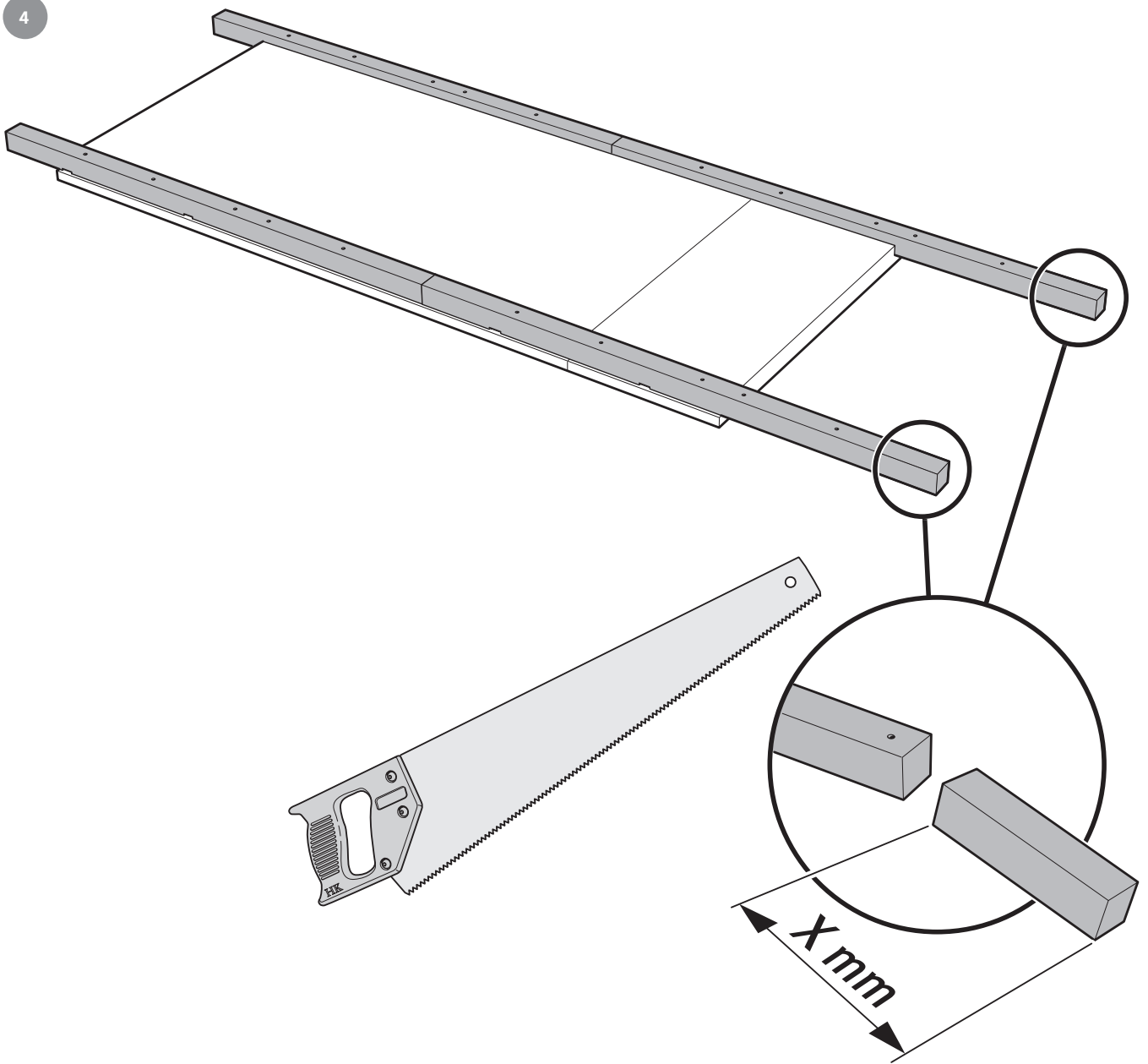

$X = 2500 \text{ mm} - H$



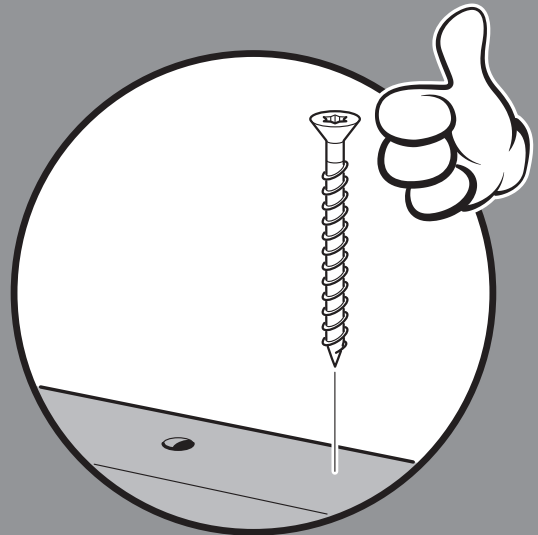
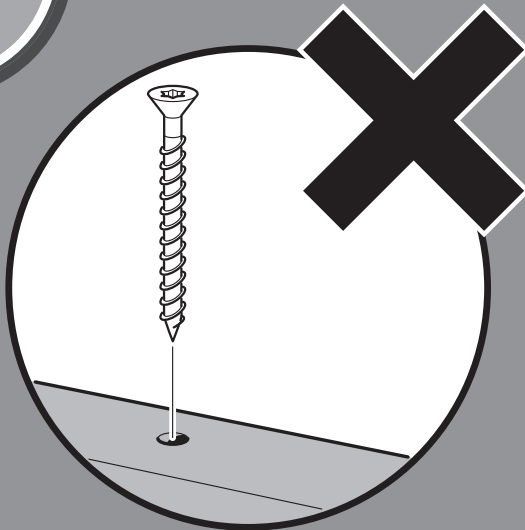
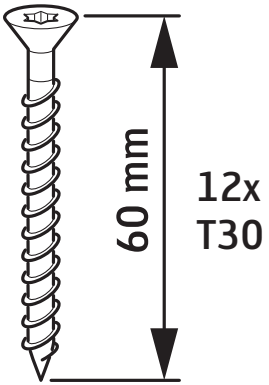
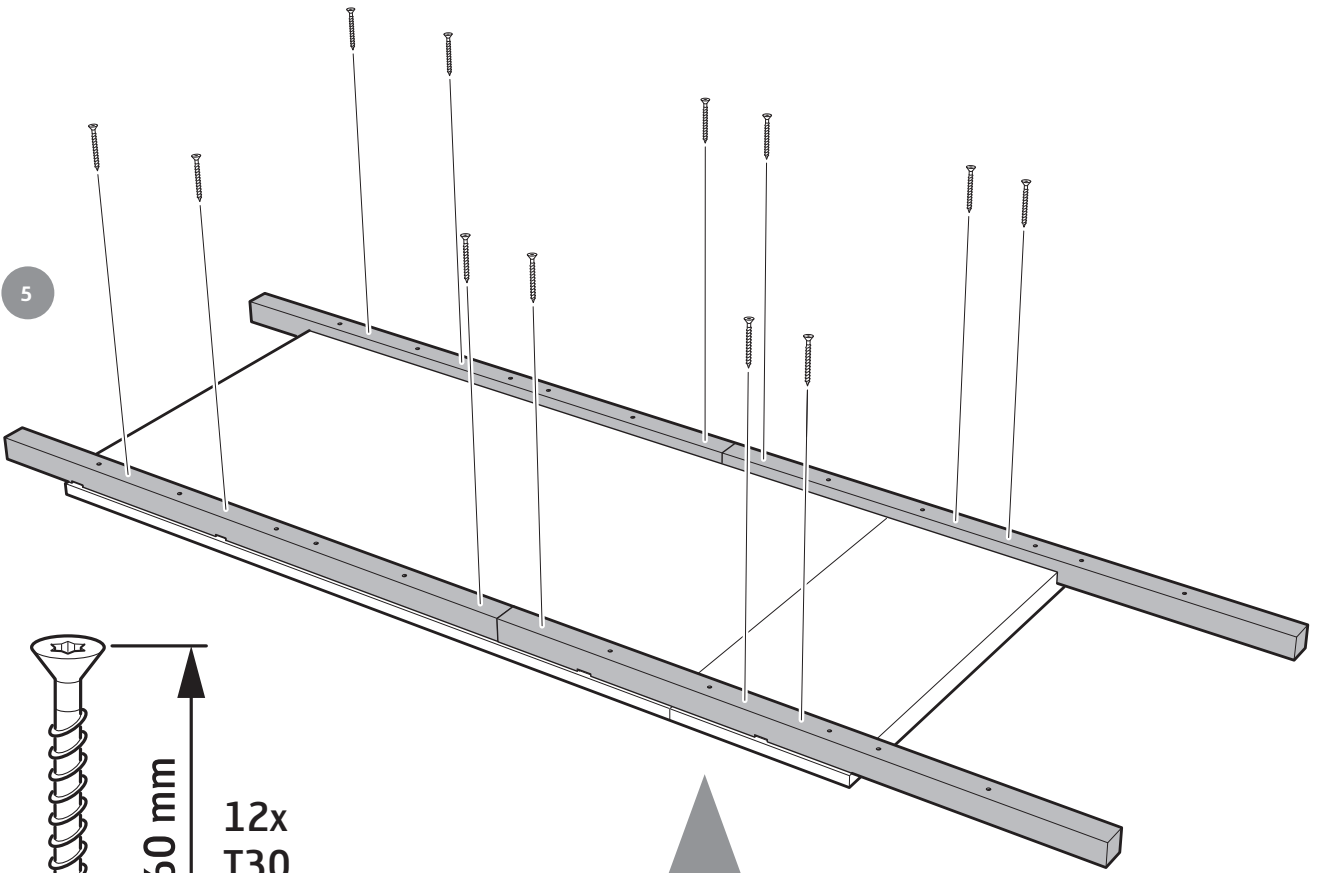



6

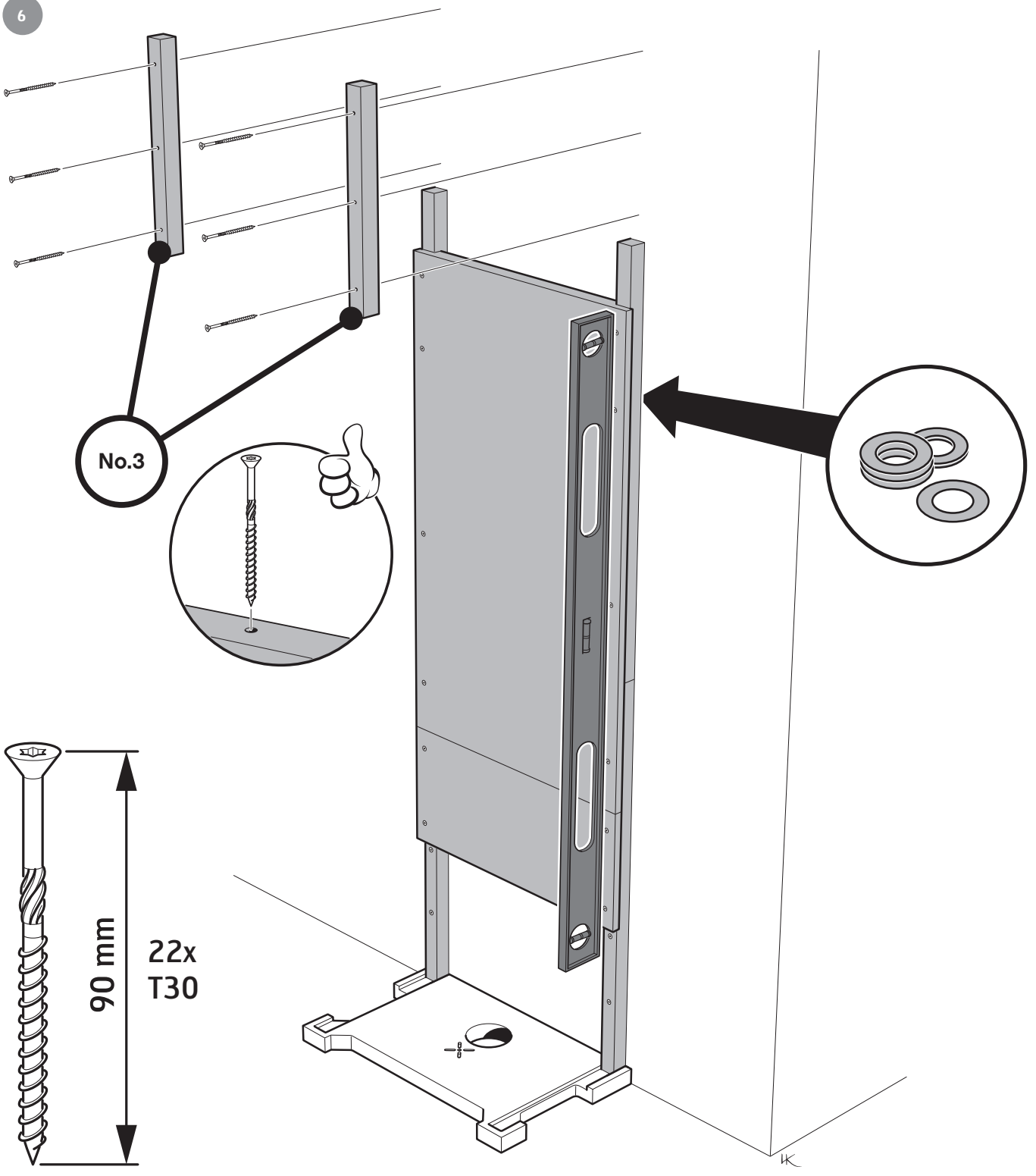



7

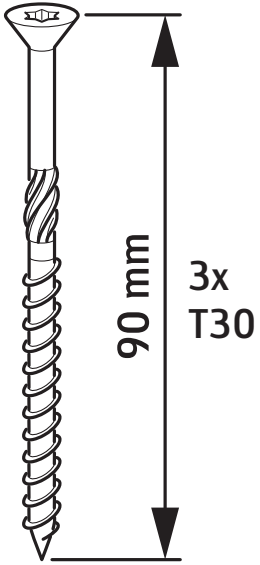

No.5

No.5.2

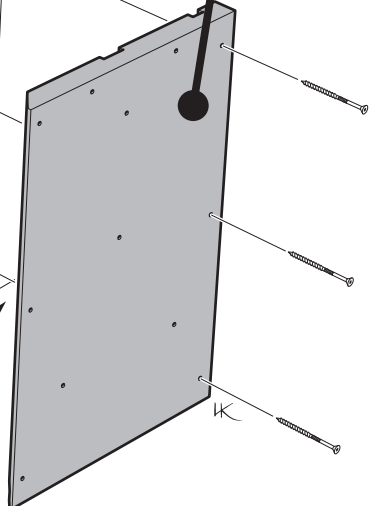
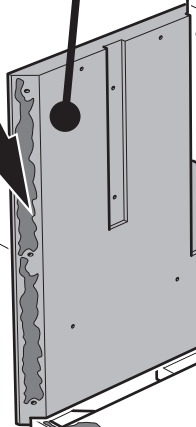
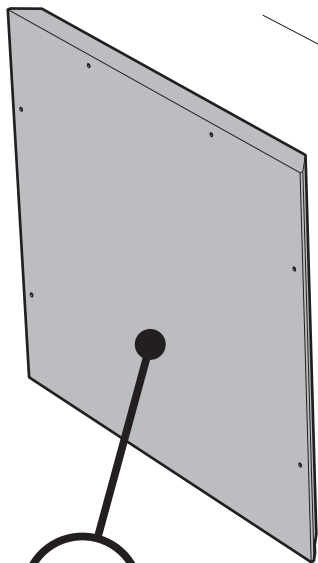



8

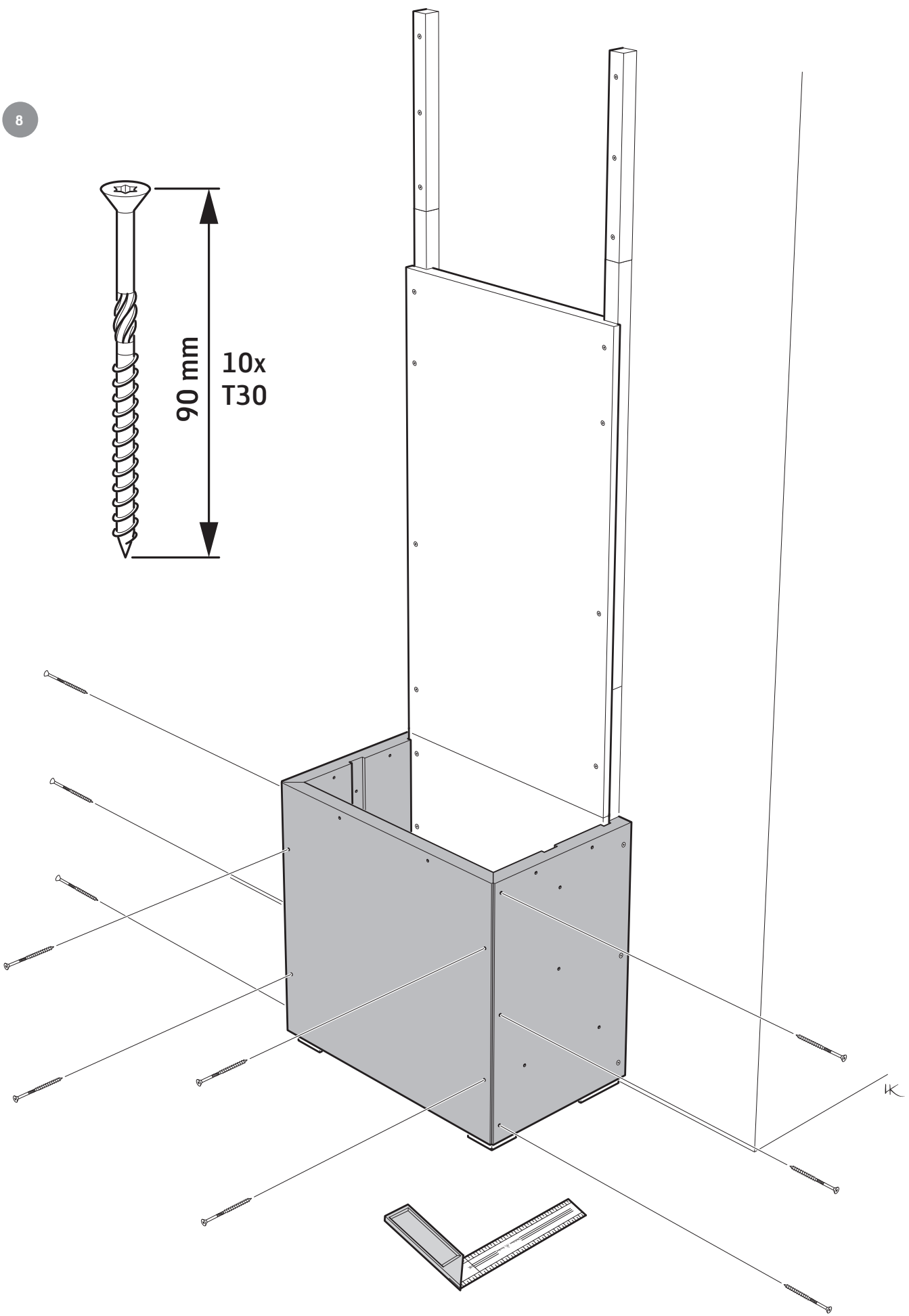
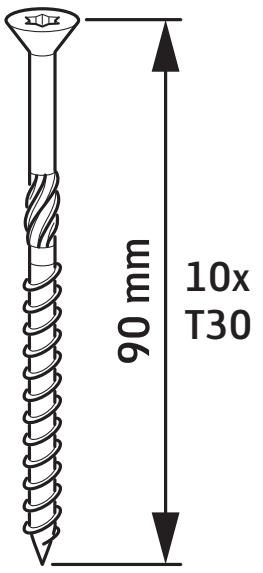



9

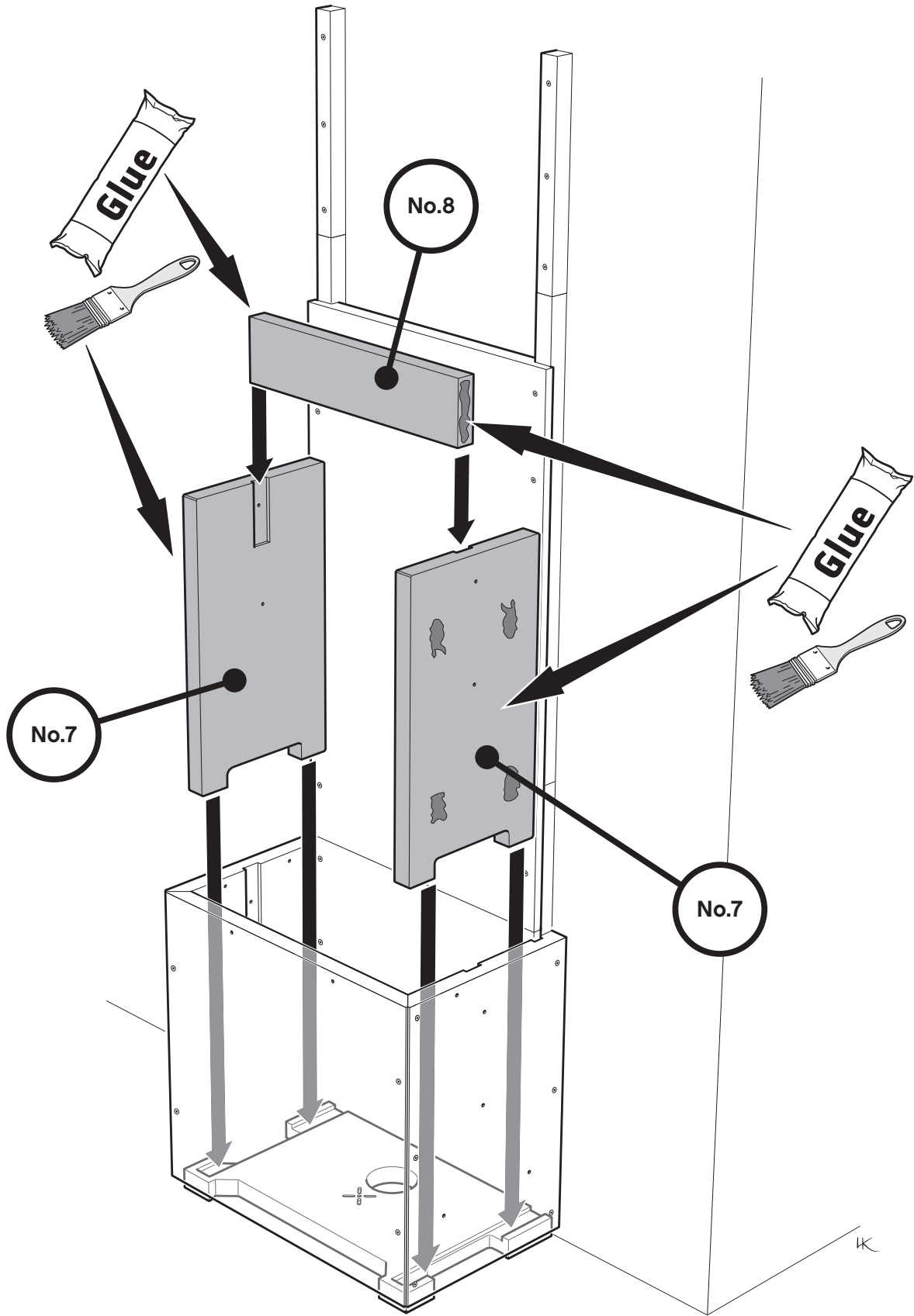



10

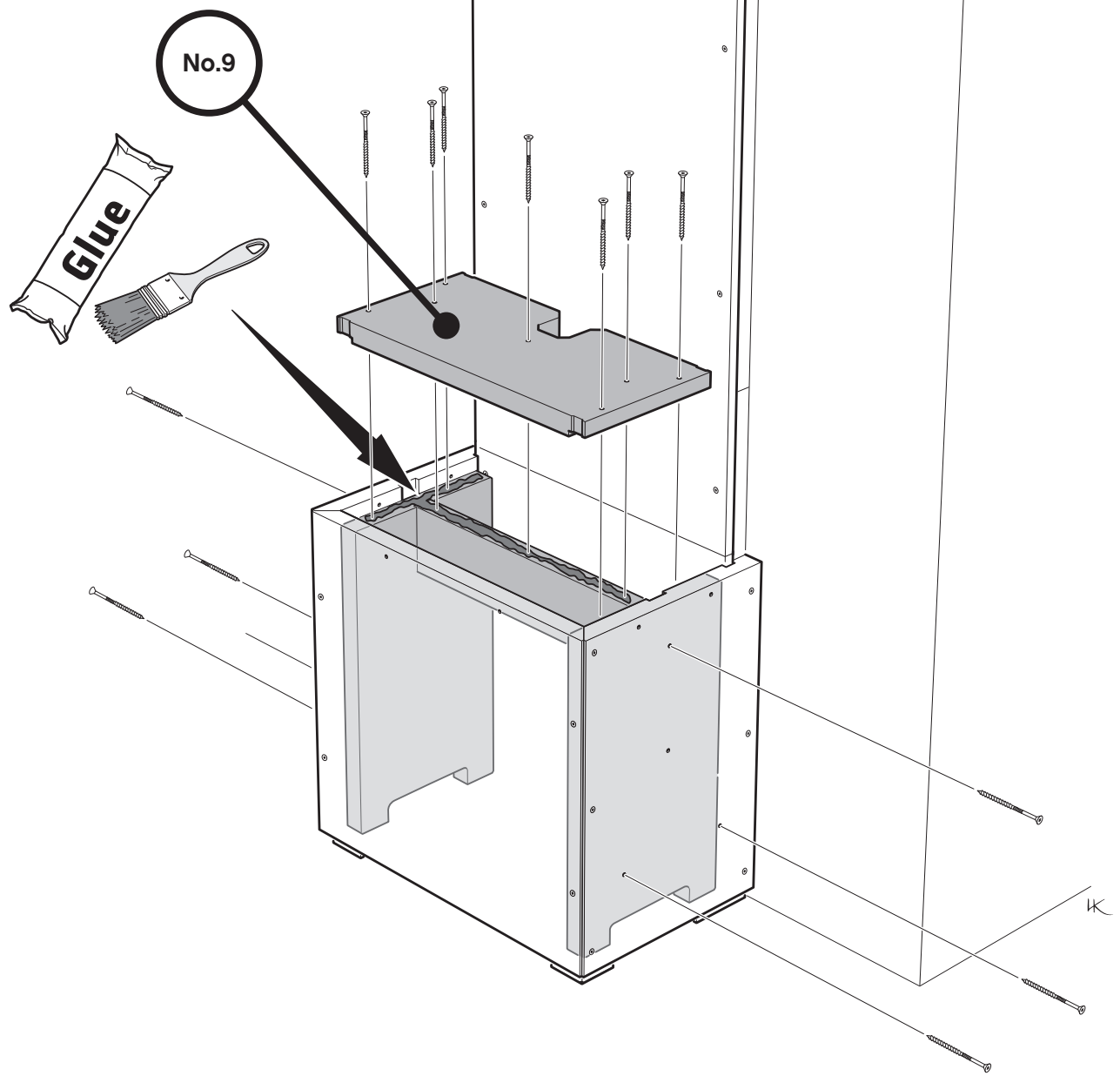
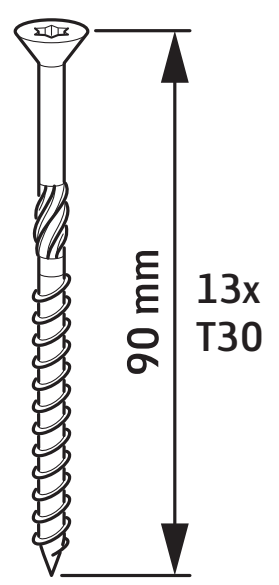



11

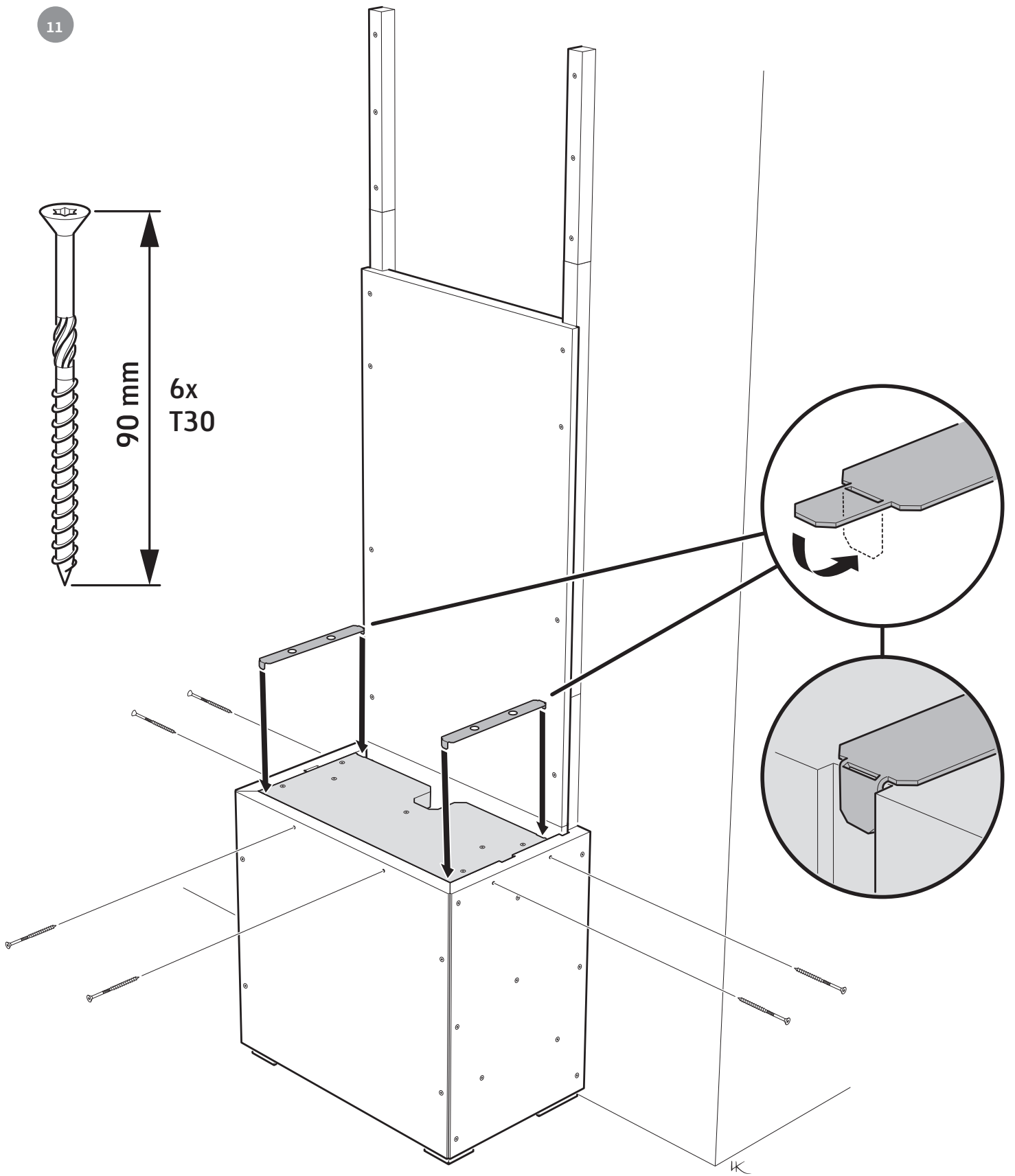



12

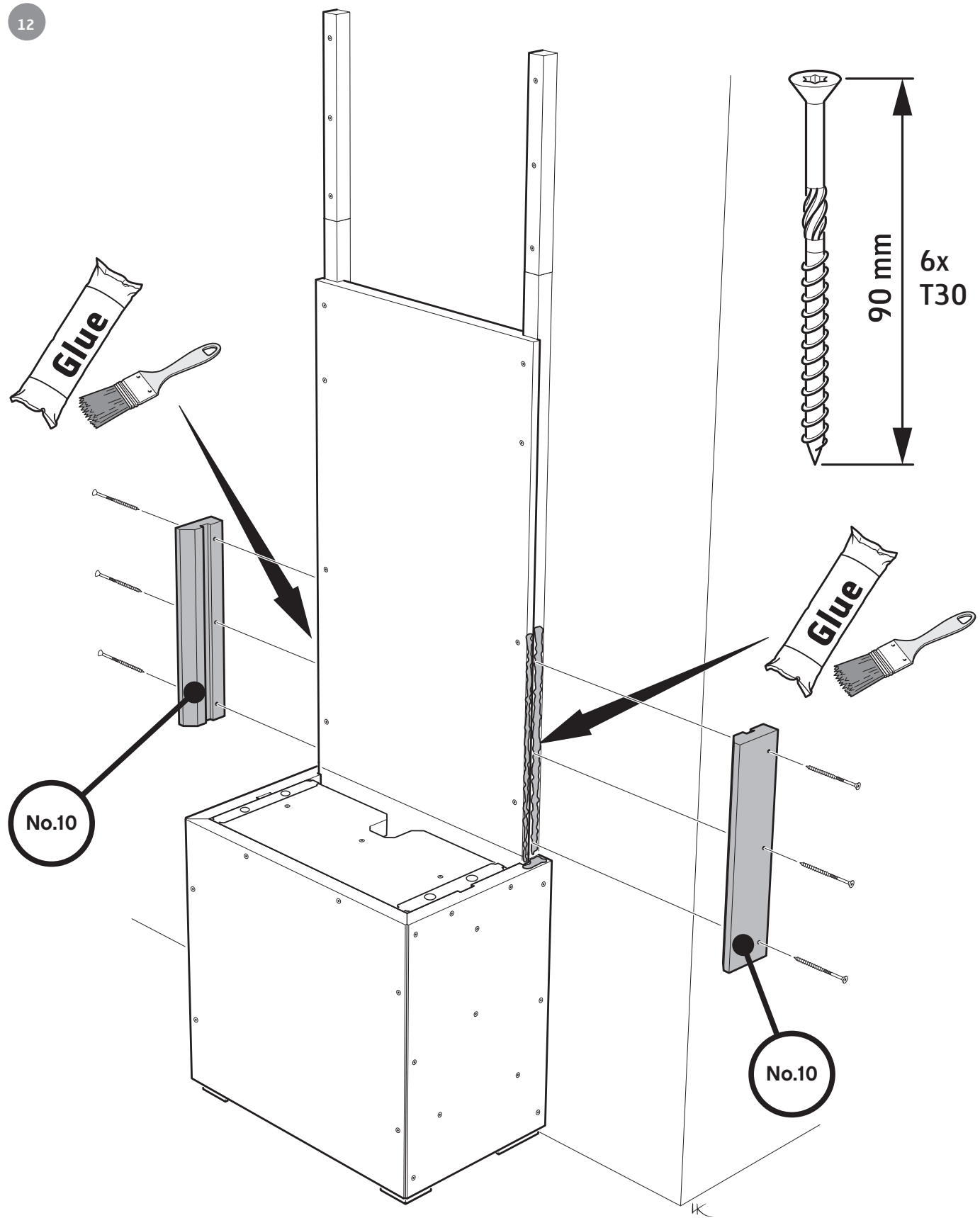





13

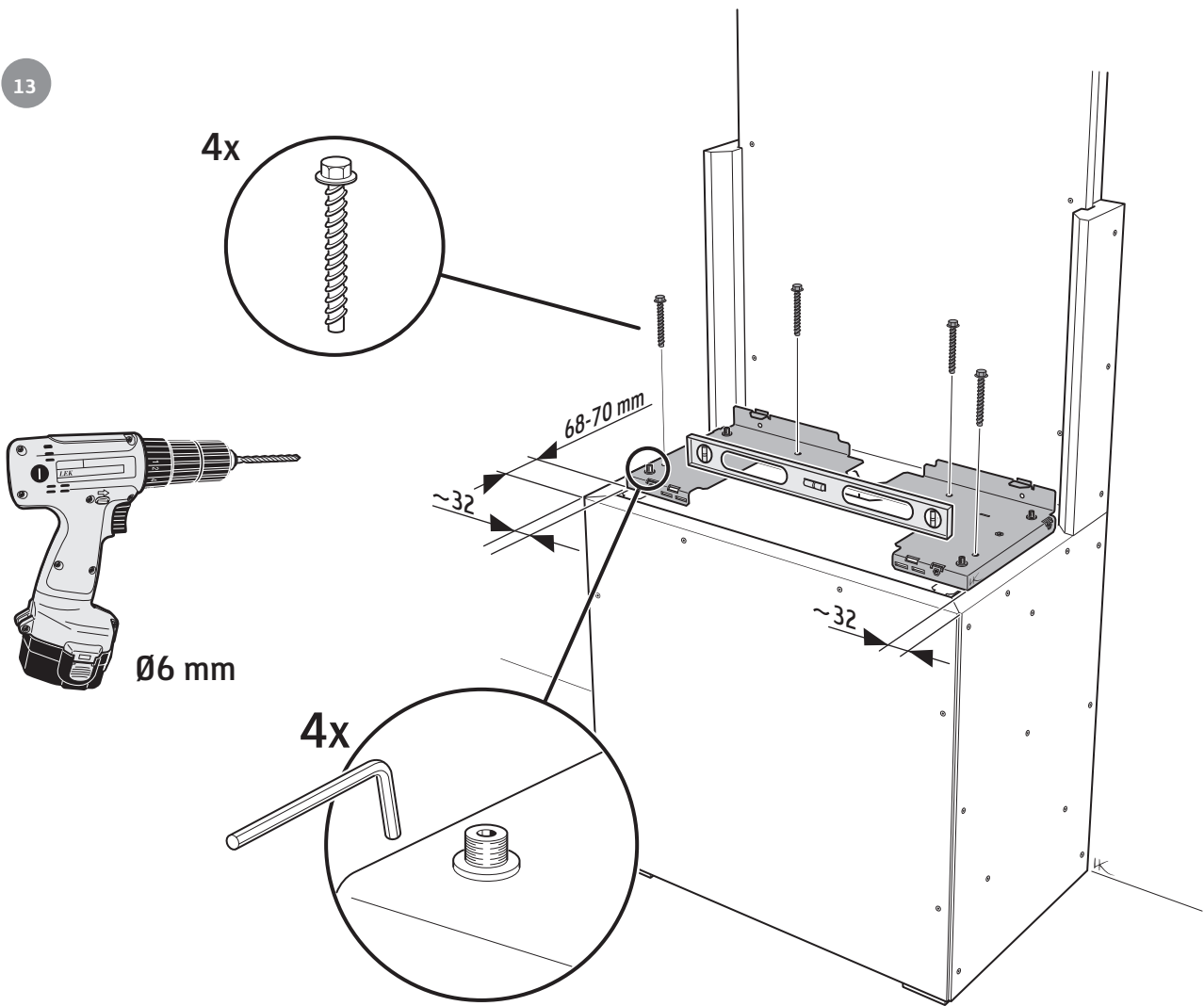

SE

## Alternativ monteringsföljd

För att underlätta spackling och slipning kring kassetten ram kan detta göras innan kassetten monteras och ansluts. Kassettmontaget utförs i detta fall efter Moment 19. När hela omramningen är monterad färdigställs spackling.

DE

## Alternative Einbaureihenfolge

Für ein leichteres Spachteln und Schleifen um den Rahmen der Kassette können diese Arbeiten vor Einbau und Anschluss der Kassette erfolgen. Der Einbau der Kassette wird in diesem Fall nach Arbeitsschritt 19 ausgeführt. Die Spachtelarbeiten werden nach dem abschließenden Einbau der Verkleidung fertiggestellt.

NO

## Alternativ monteringsrækkefølge

Før å gjøre det enklere å sparkle og slipe rundt kassettrammen kan dette gjøres før kassetten monteres og tilkobles. Monteringen av kassetten utføres i så fall etter moment 19. Når hele omramningen er montert, ferdigstilles sparklingen.

GB

## Alternative assembly sequence

It is easier to do filling and sanding work around the cassette frame before the cassette is installed and connected. In this case, the cassette is installed after Step 19. Complete the filling work after the entire surround has been installed.

DK

## Alternativ monteringsrækkefølge

Før at lette spartling og slibning omkring kassetten ramme kan dette foretages, før kassetten monteres og tilsluttes. Kassettemontagen udføres i dette tilfælde efter Punkt 19. Når hele omramningen er monteret, spartles der færdigt.

FR

## Séquence de montage alternative

Effectuer la pose de joints mastic et le ponçage autour du cadre de l'insert, avant de monter et de raccorder ce dernier, pour plus de facilité. Le montage de l'insert est dans ce cas effectué après le point 19. Lorsque l'habillage est en place, terminer la pose de joints mastic.

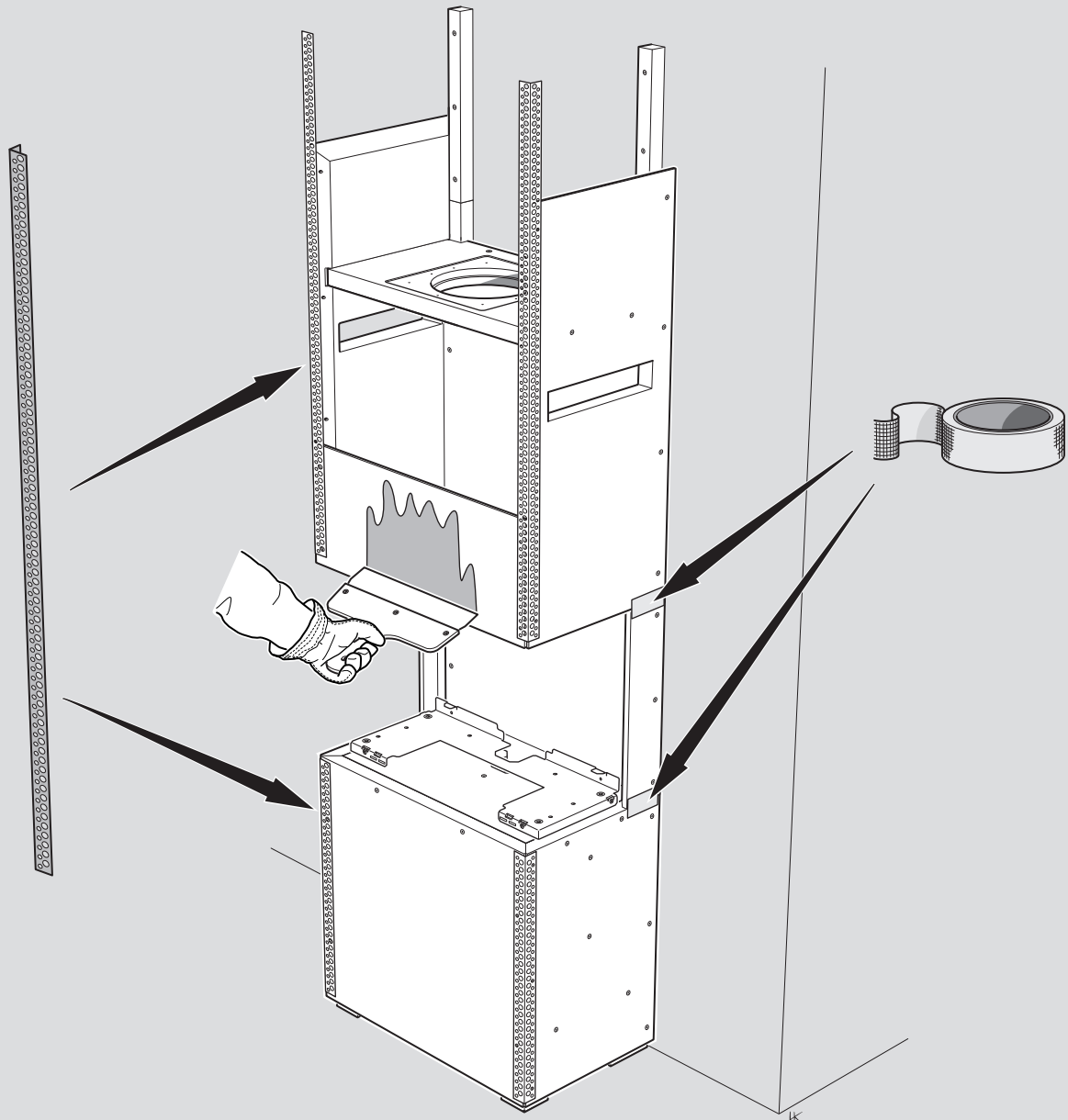

FI

**Vaihtoehtoinen asennusjärjestys**

Takkasydämen kehysten ympäristön kitkaamisen ja hionnan helpottamiseksi sen voi tehdä ennen takkasydämen asennusta ja liittämistä. Takkasydän asennetaan siinä tapauksessa vaiheen 19 mukaan. Kitkaus suoritetaan loppuun, kun koko kuori on asennettu.

IT

**Sequenza alternativa di montaggio**

Per facilitare la stuccatura e la levigatura del telaio dell'insero, è possibile effettuare queste operazioni prima che l'insero sia montato e collegato. In questo caso, il montaggio dell'insero sarà fatto dopo il Passo 19. Quando tutto il telaio è montato, si completa la stuccatura.

NL

**Alternatieve montagevolgorde**

Om het voegen en schuren rond de omlijsting van de inzethaard te vergemakkelijken, kan dat worden gedaan vóór de montage en aansluiting van de inzethaard. De montage van de inzethaard wordt dan uitgevoerd na stap 19. Als de volledige omlijsting gemonteerd, wordt deze verder afgevoegd.

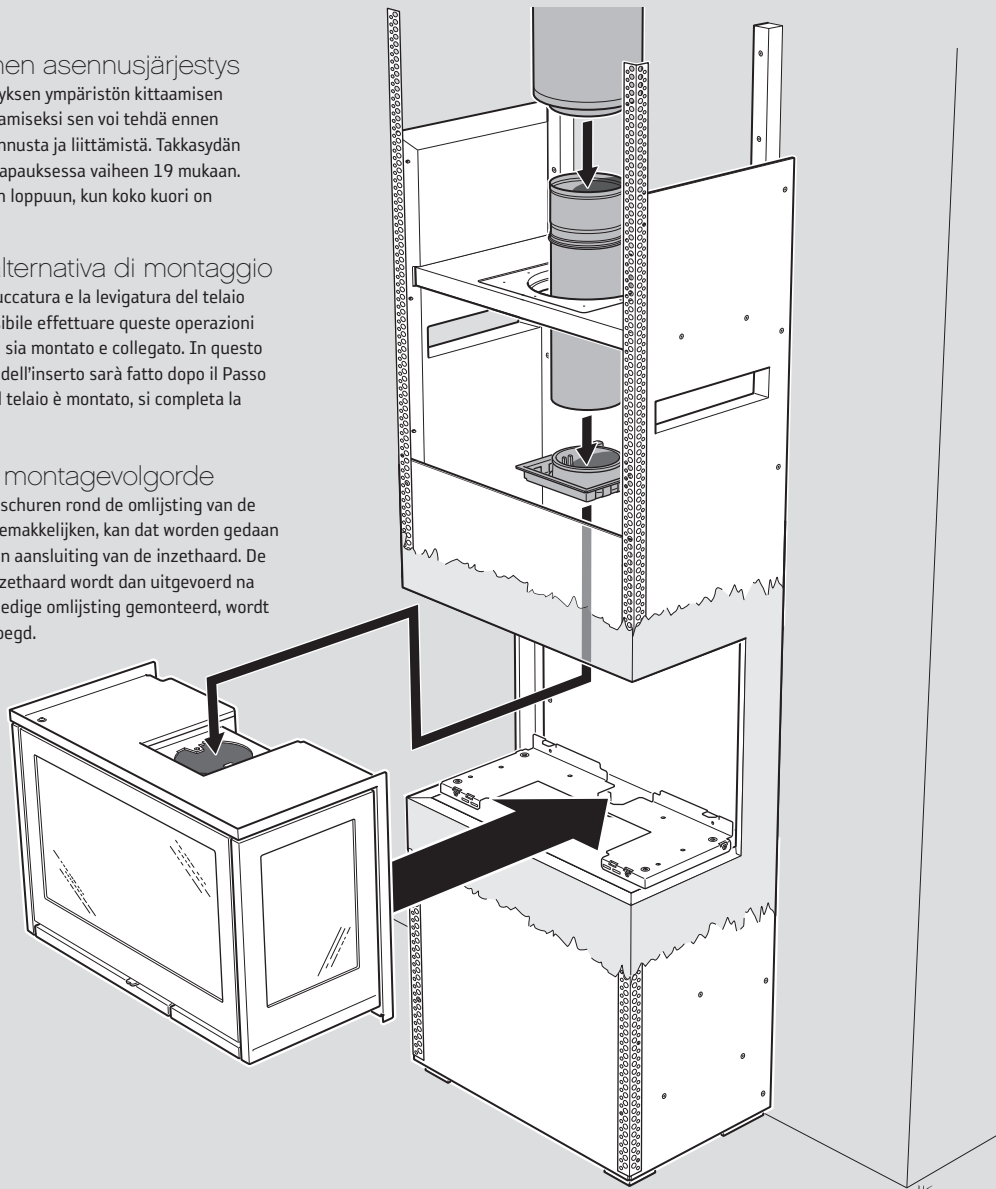

14

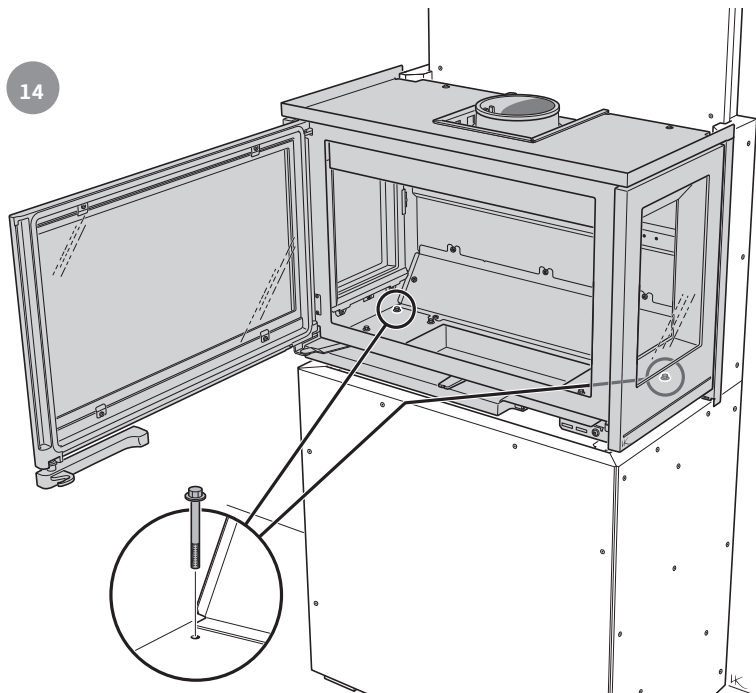



15

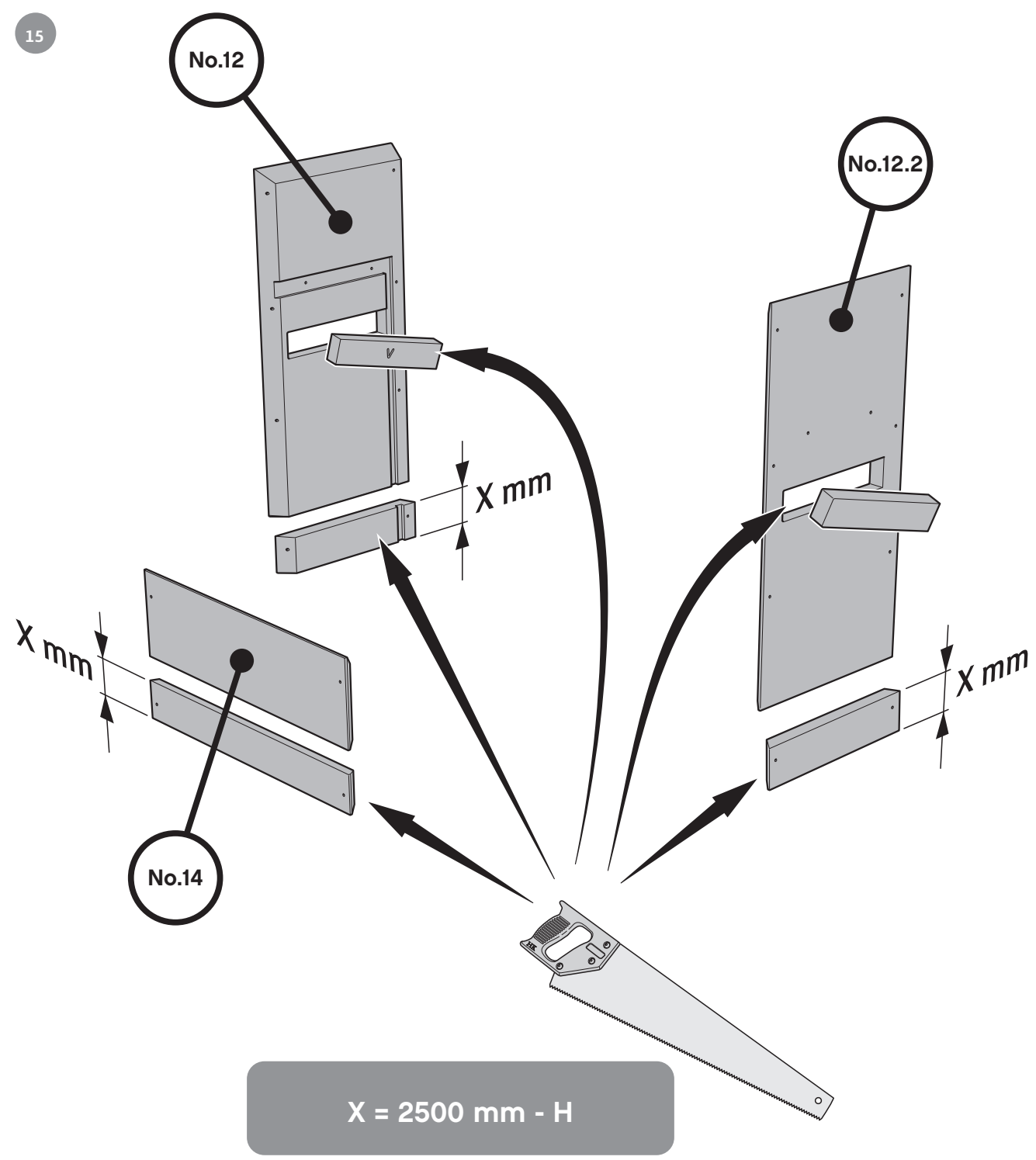

$X = 2500 \text{ mm} - H$



16

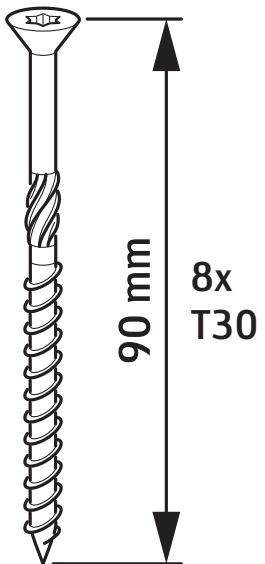
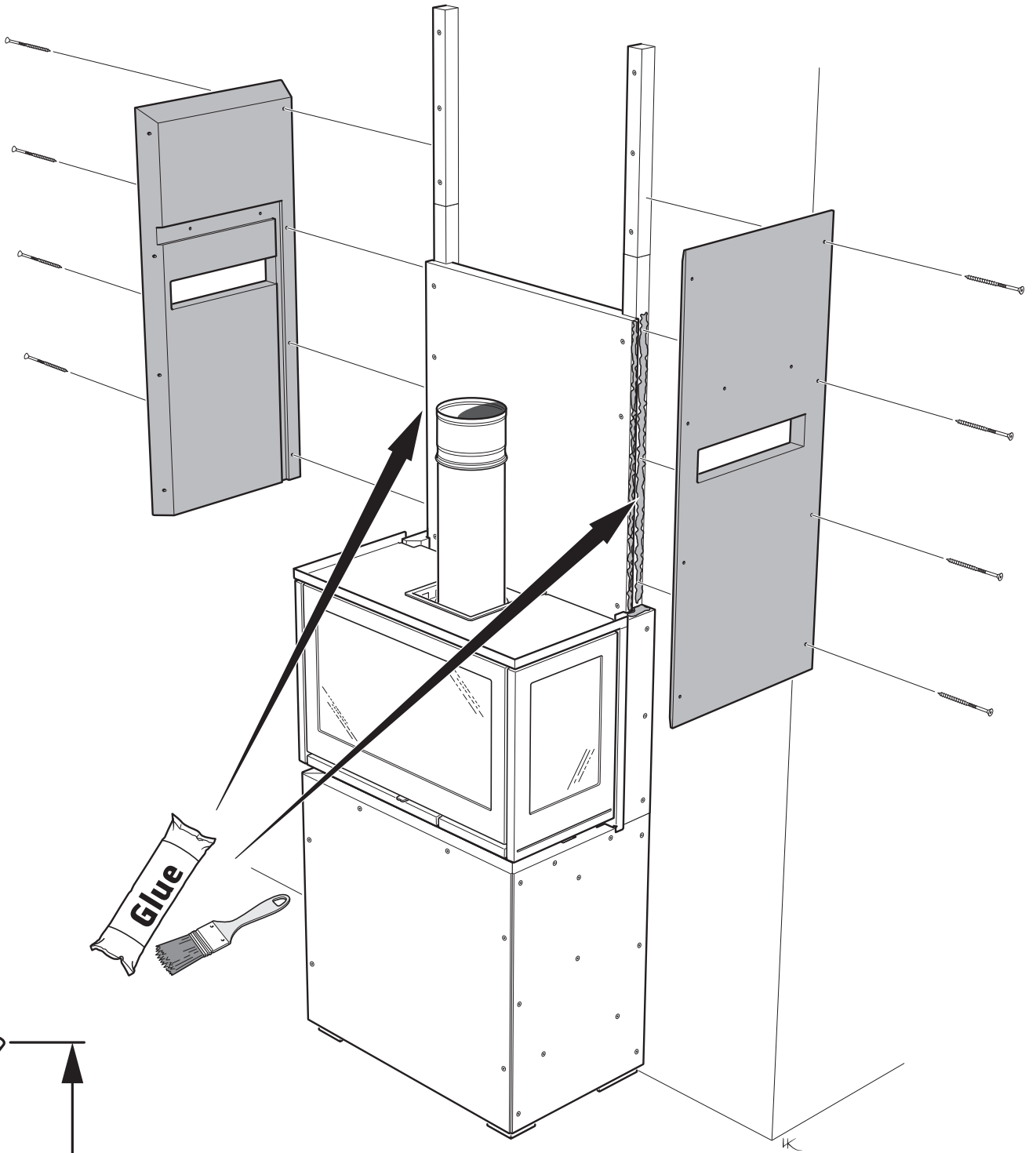



17

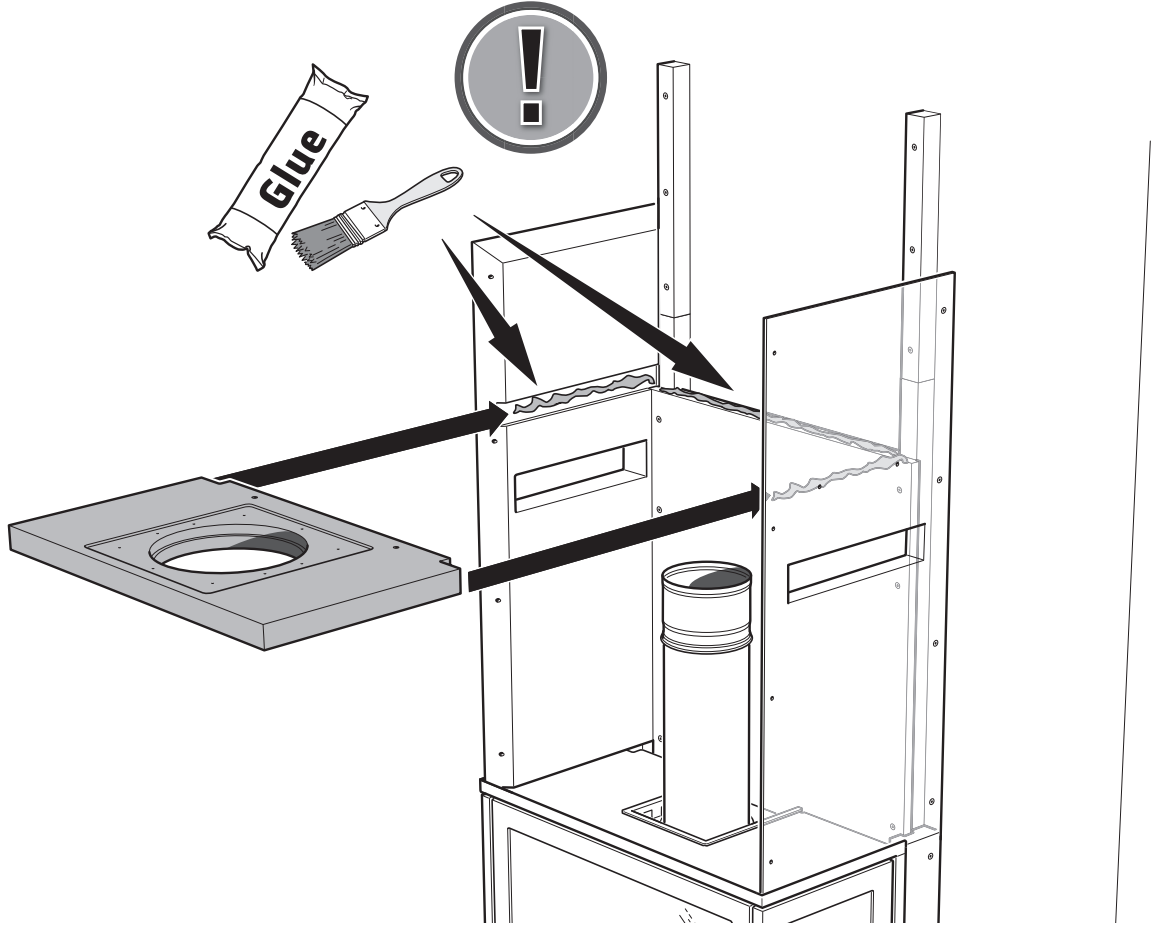

18

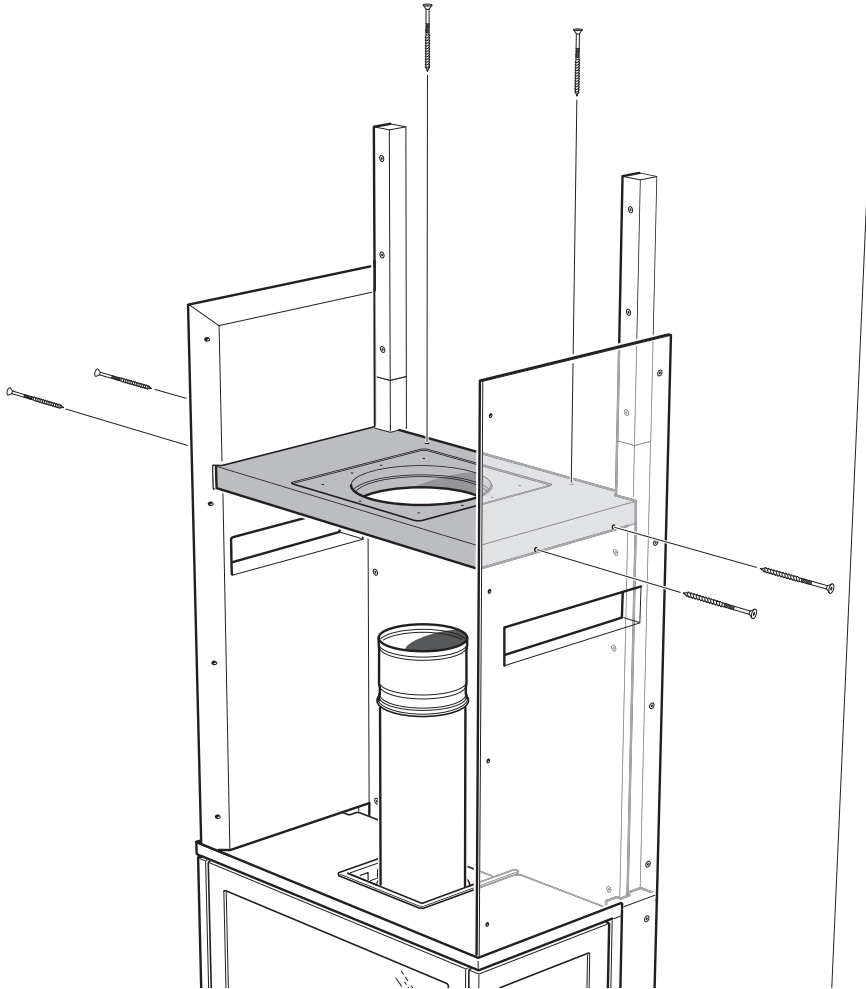
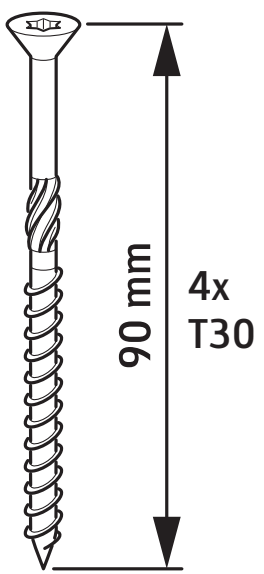



19

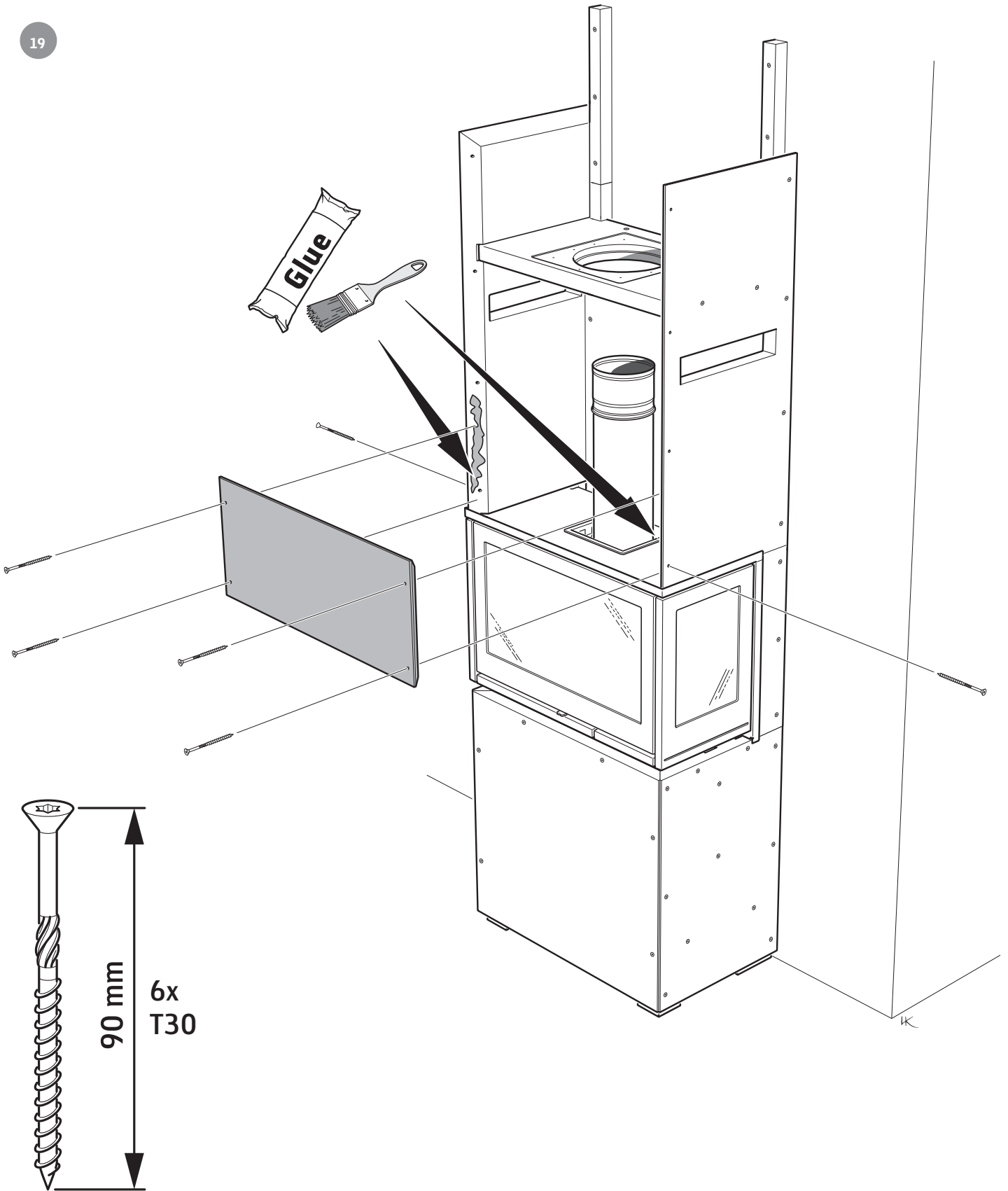

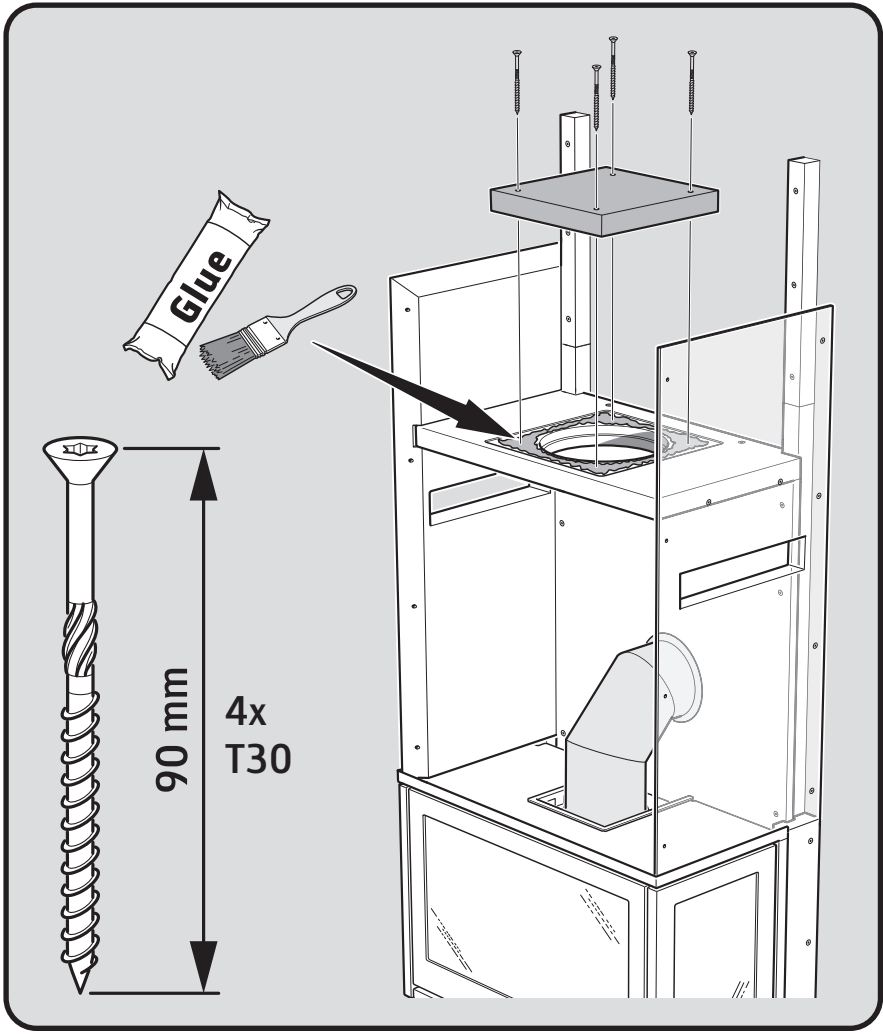

20

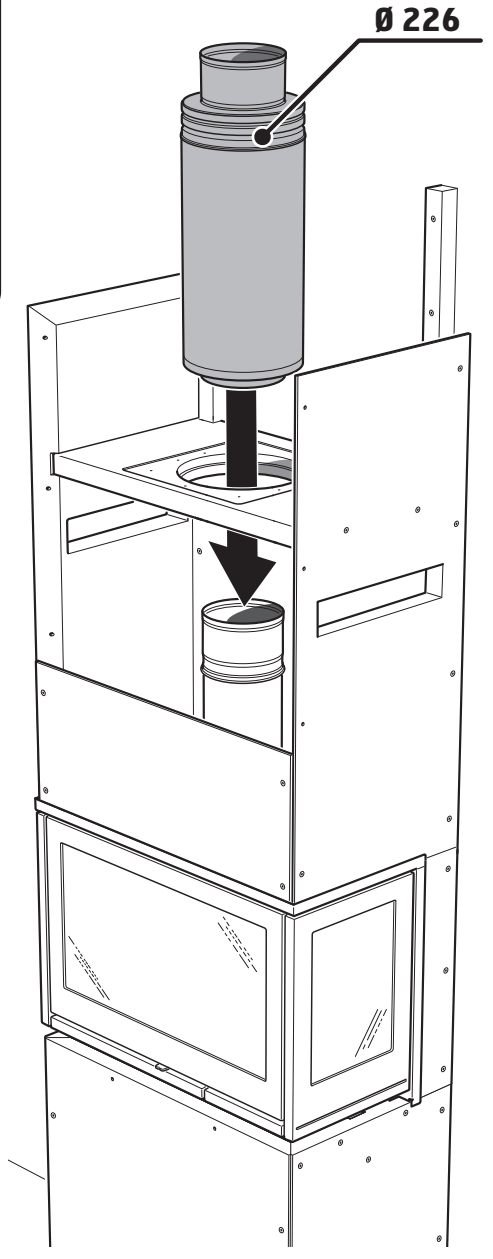





21

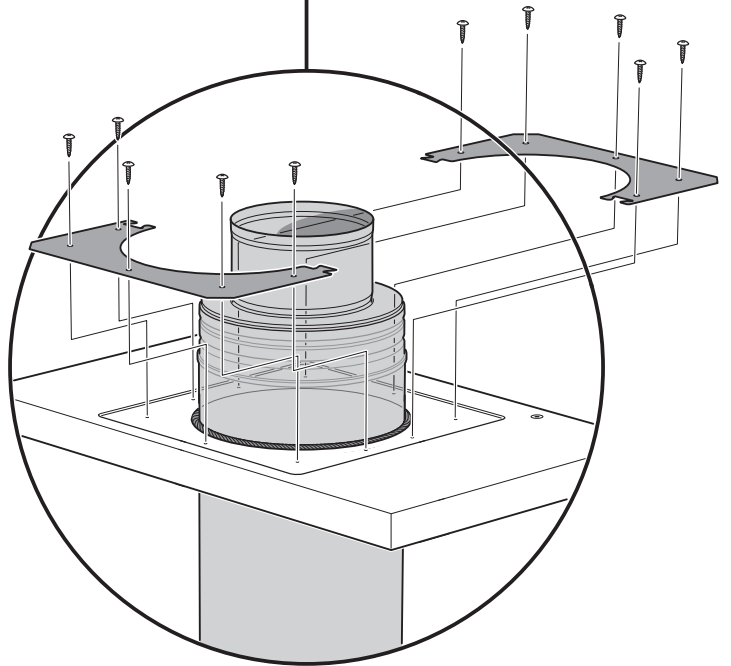
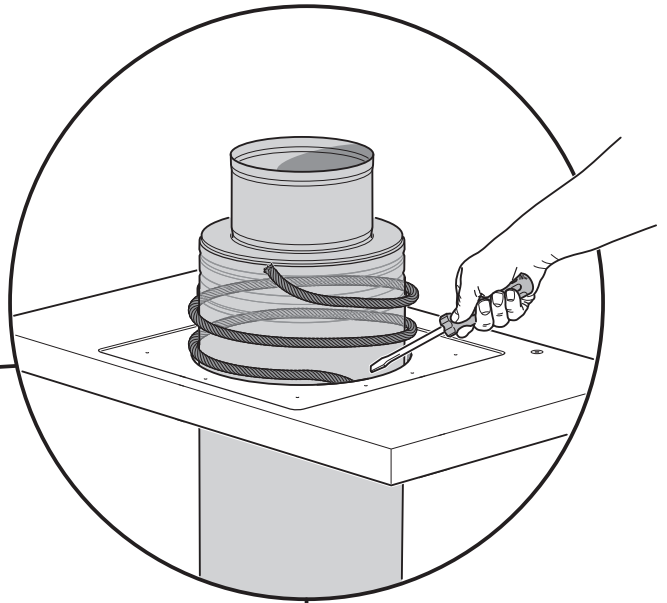
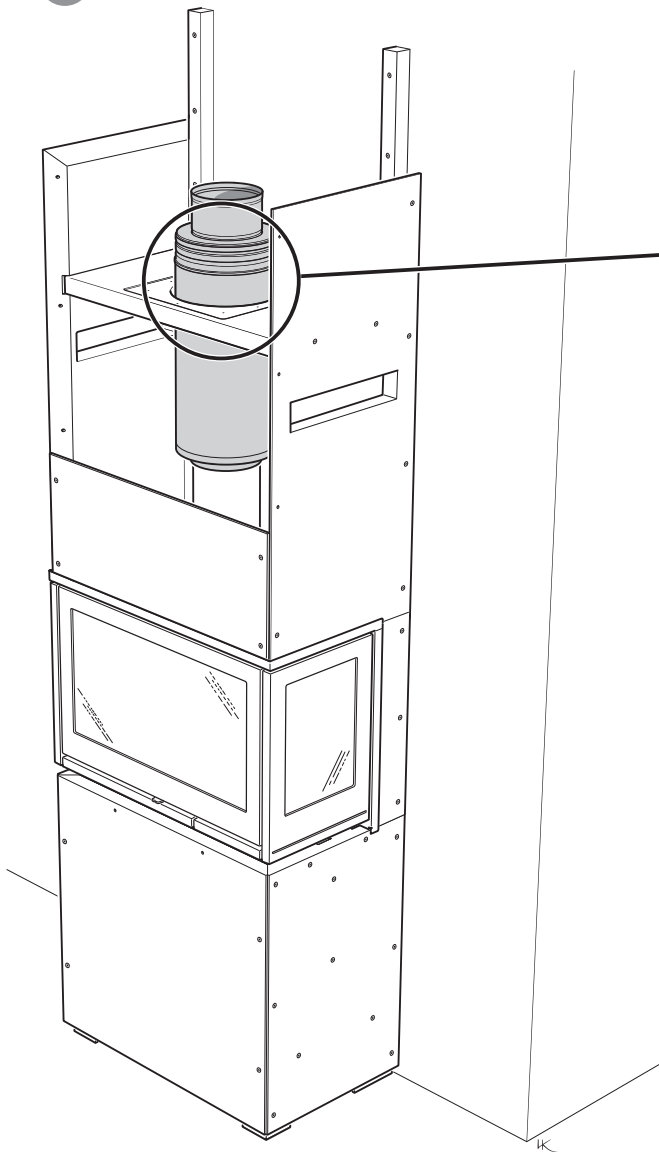



22

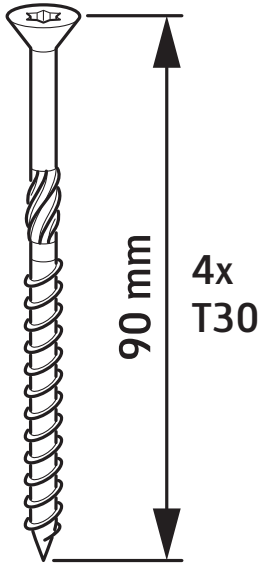
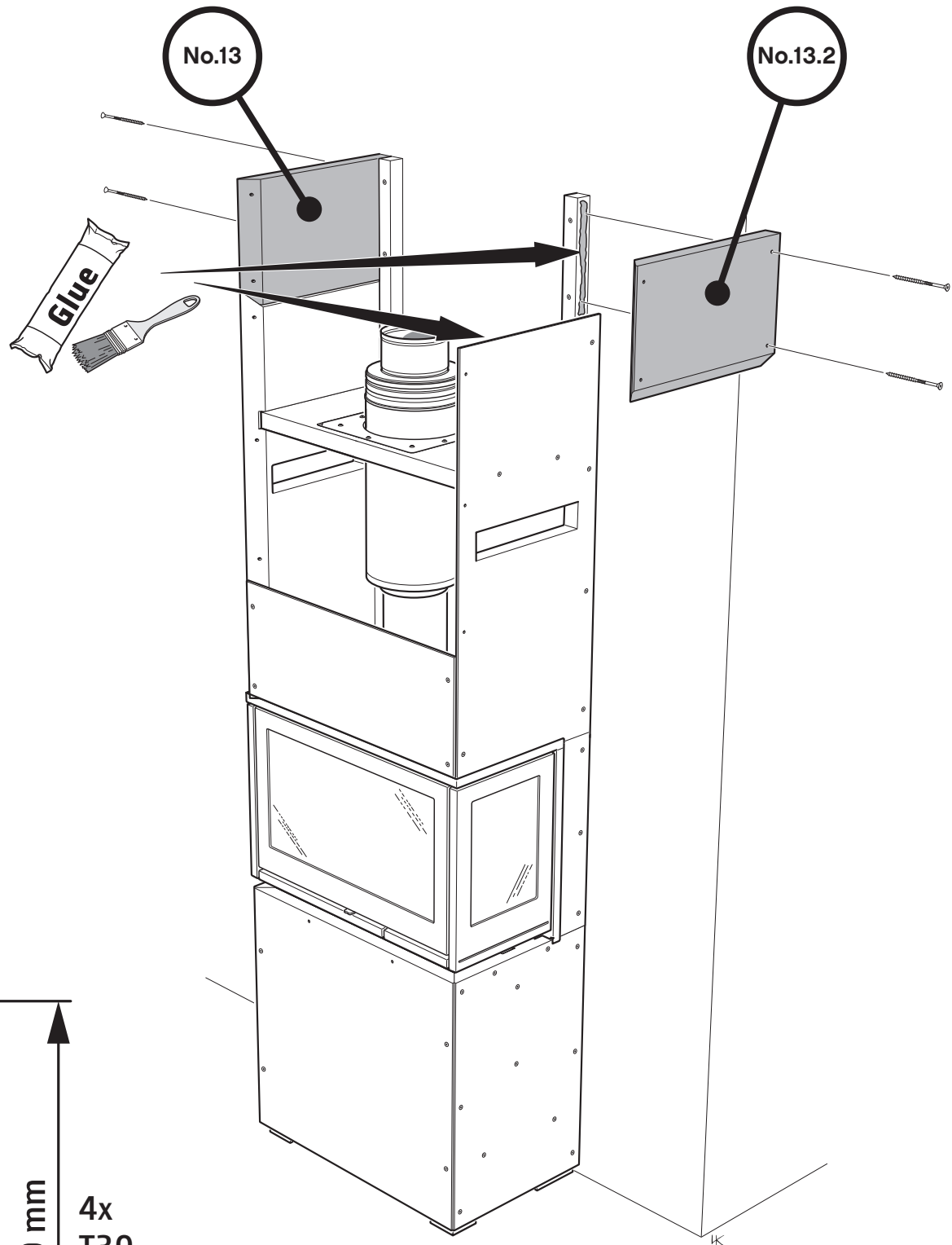



23

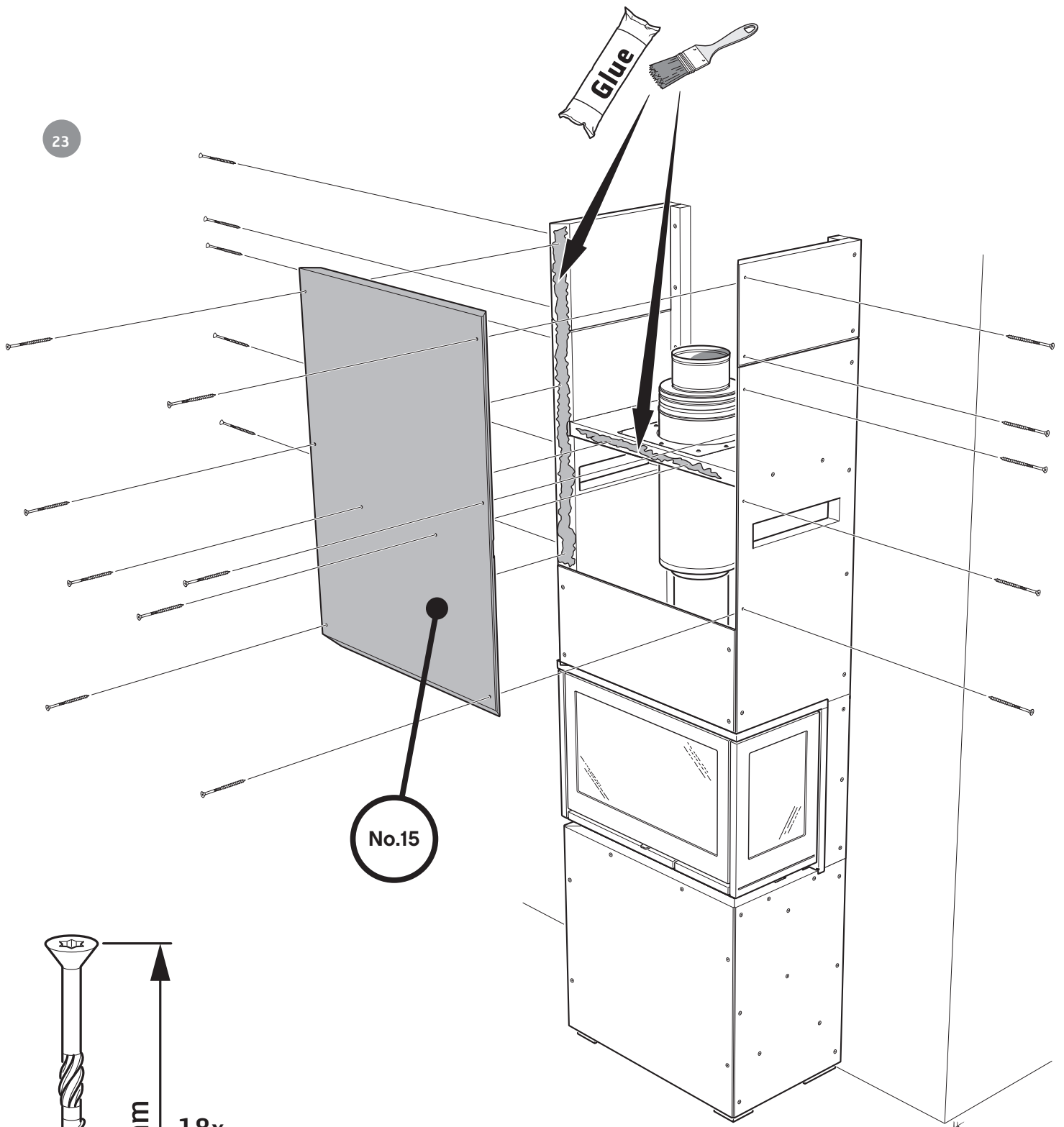

No.15

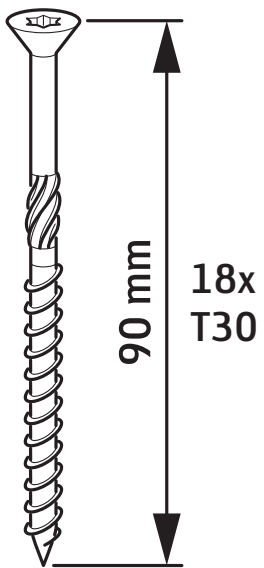

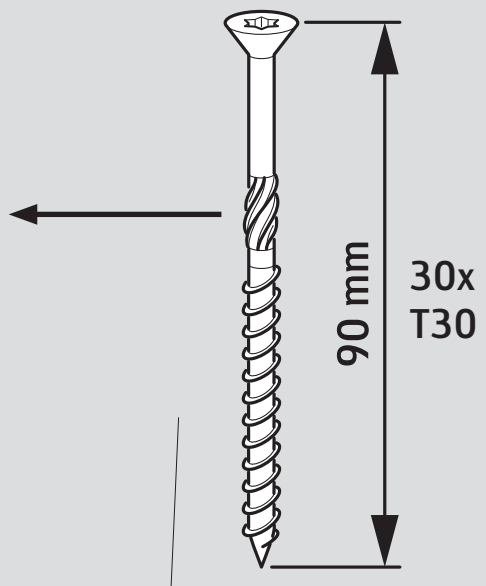
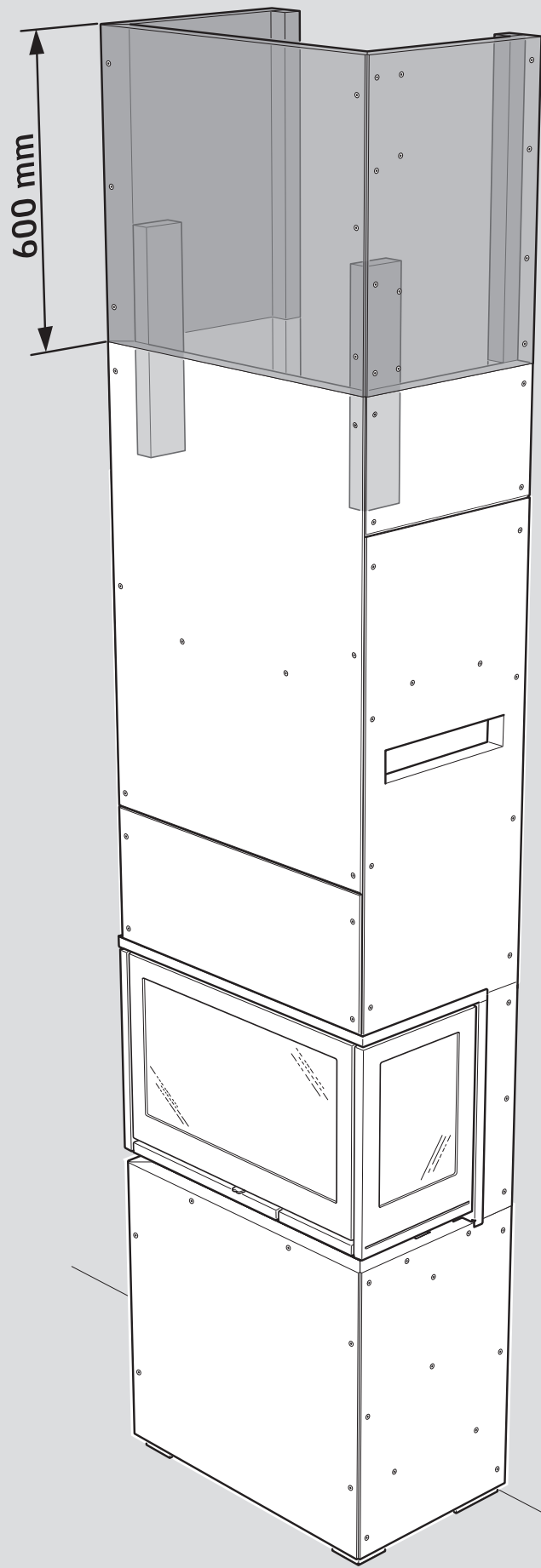

- SE Tillval
- DE Sonderzubehör
- NO Tilbehør
- FR Option
- GB Option
- DK Ekstraudstyr
- FI Lisävaruste
- IT Optional
- NL Optie

K



24

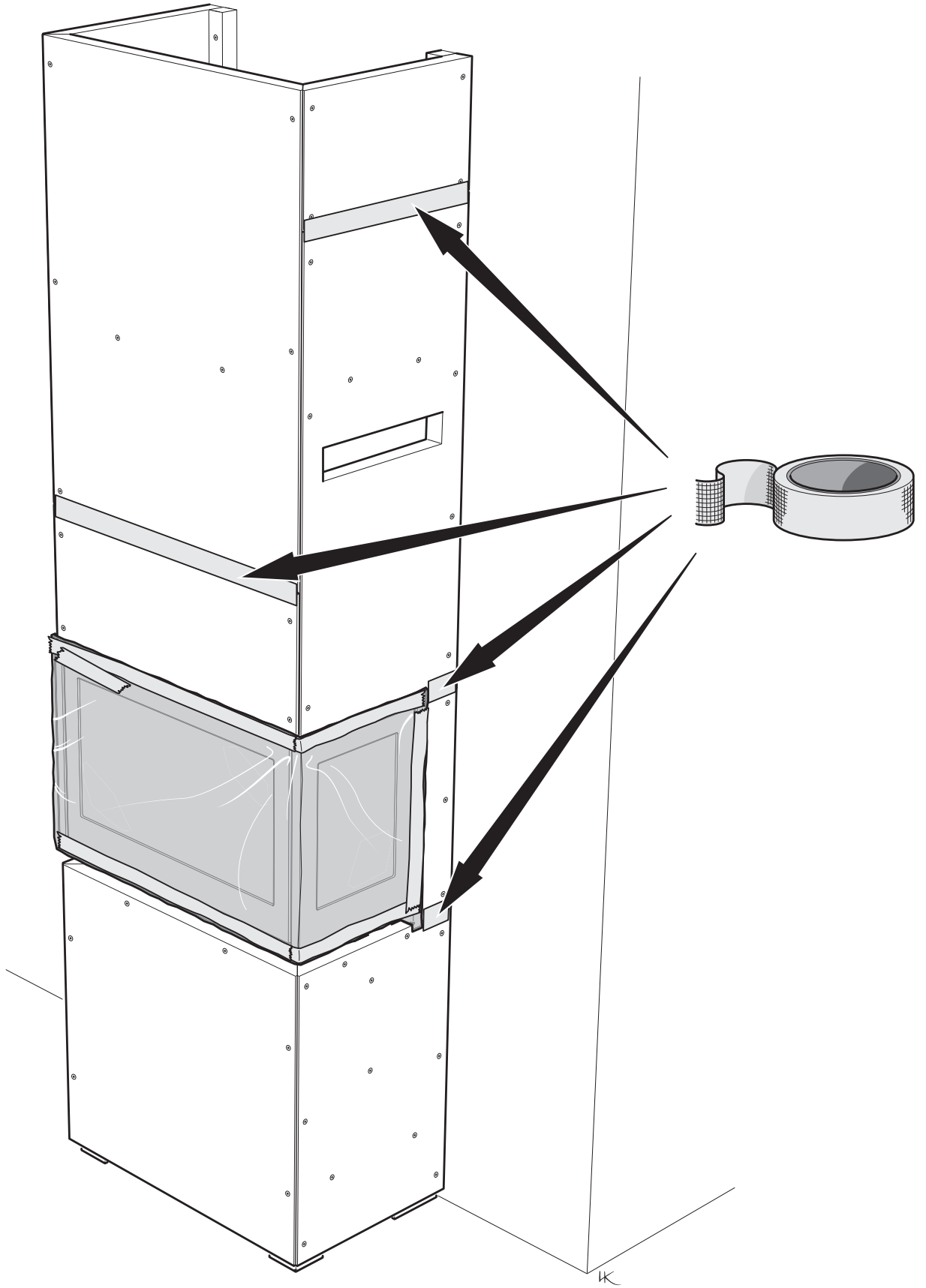



25

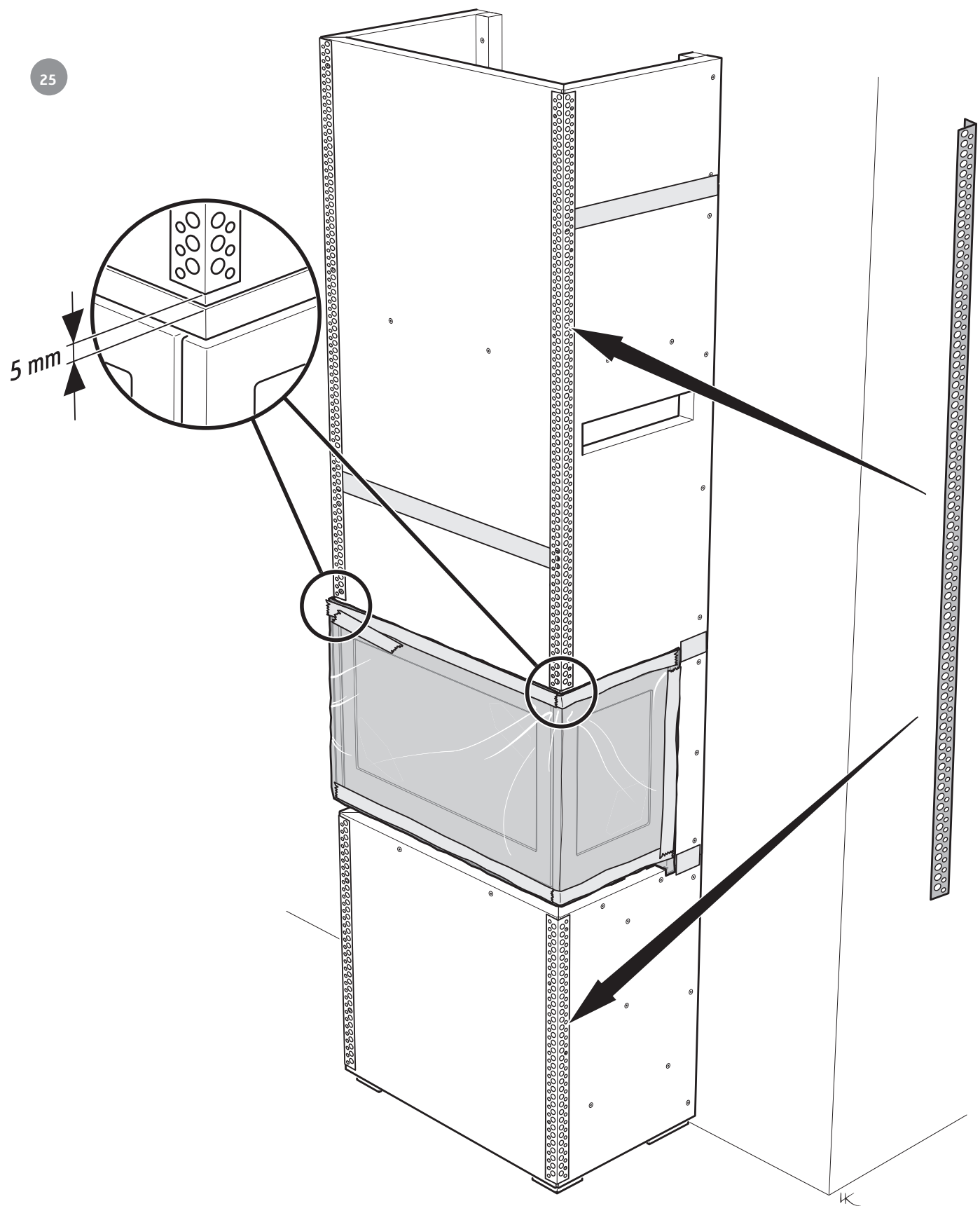



**SE** Plattorna är förbehandlade med en primer och kräver därför ingen ytterligare ytbehandling före spackling.

**DE** Die Platten wurden mit einem Primer vorbehandelt und bedürfen deswegen vor dem Spachteln keiner weiteren Oberflächenbehandlung.

**NO** Platene er forbehandlet med en primer og krever derfor ingen ytterligere overflatebehandling før sparkling.

**FR** Les panneaux sont revêtus d'un apprêt et n'exigent donc aucun traitement de surface supplémentaire avant l'application de mastic.

**GB** The boards are pre-primed and therefore ready to be plastered without any other preparation.

**DK** Pladerne er forbehandlet med en primer og kræver derfor ingen yderligere overfladebehandling før spartling.

**FI** Levyt on esikäsitelty pohjamaalilla, joten ne eivät vaadi mitään ylimääräistä pintakäsittelyä ennen kittausta.

**IT** Le piastre sono pre-trattate con un primer, quindi non è necessario alcun trattamento prima di stuccare.

**NL** De platen zijn voorbehandeld met een primer en hebben daardoor vóór het plamuren geen verdere behandeling nodig.

26

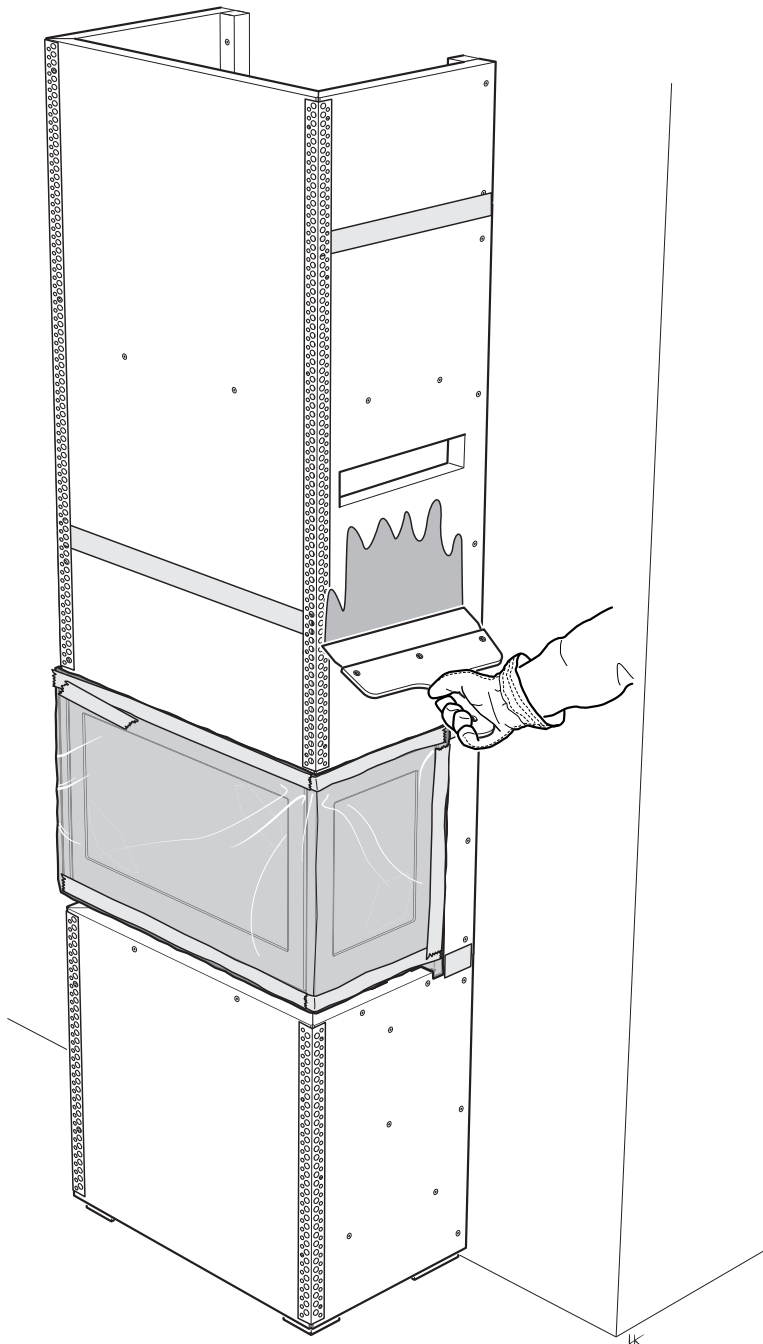

27

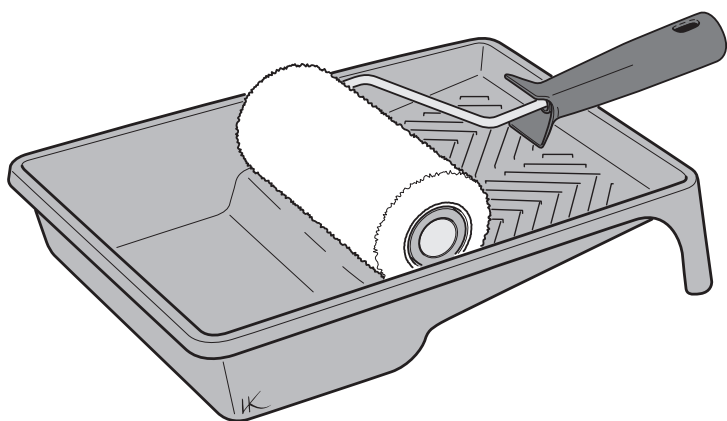

SE

**Lackering**

När eldstaden spacklats och slipats med sandpapper kan du måla eldstaden. Använd diffusionsöppen färg (akryl) som är avsedd för murverk.

DE

**Lackieren**

Der Kaminofen kann nach Fertigstellung der Spachtel- und Schleifarbeiten lackiert werden. Verwenden Sie diffusionsoffene Farbe (Acryl) für Mauerwerk.

NO

**Lakkering**

Når ildstedet er sparklet og slipt med sandpapir, kan du male det. Bruk diffusionsåpen maling (akryl) som er beregnet for murverk.

FR

**Peinture**

L'habillage de l'insert peut être peint après avoir appliqué les joints mastic et poncé les surfaces avec du papier de verre. Utiliser de la peinture perméable à la diffusion de vapeur d'eau (acrylique) destinée à la maçonnerie.

GB

**Painting**

When the fireplace has been filled and sanded down with sandpaper, it is ready to be painted. Use a diffusion-open paint (acrylic) that is formulated for use on masonry.

DK

**Maling**

Når ildstedet er sparklet og slebet med sandpapir, kan du male det. Benyt diffusionsåben farve (akryl), som er beregnet til murværk.

FI

**Maalaus**

Takan voi maalata kittauksen ja hionnan jälkeen. Käytä tiilirakenteille tarkoitettua diffuusioavointa (akryyli)maalia.

IT

**Verniciatura**

Quando l'inserto è stato stuccato e levigato con cartavetro, è possibile procedere alla verniciatura. Usare una vernice traspirante (acrilica) specifica per opere di muratura.

NL

**Aflakken**

Als de haard is gevoegd en geschuurd kunt u deze schilderen. Gebruik een diffusie-open verf (acryl) die geschikt is voor de stenen wanden.

28

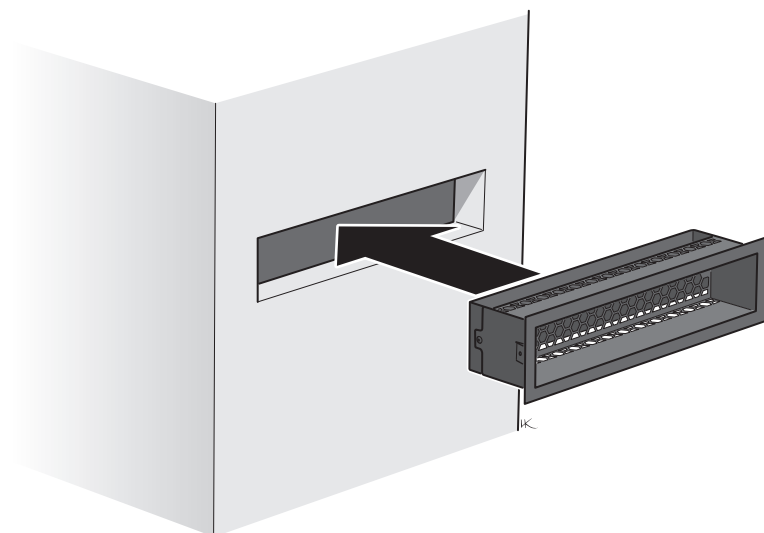





29

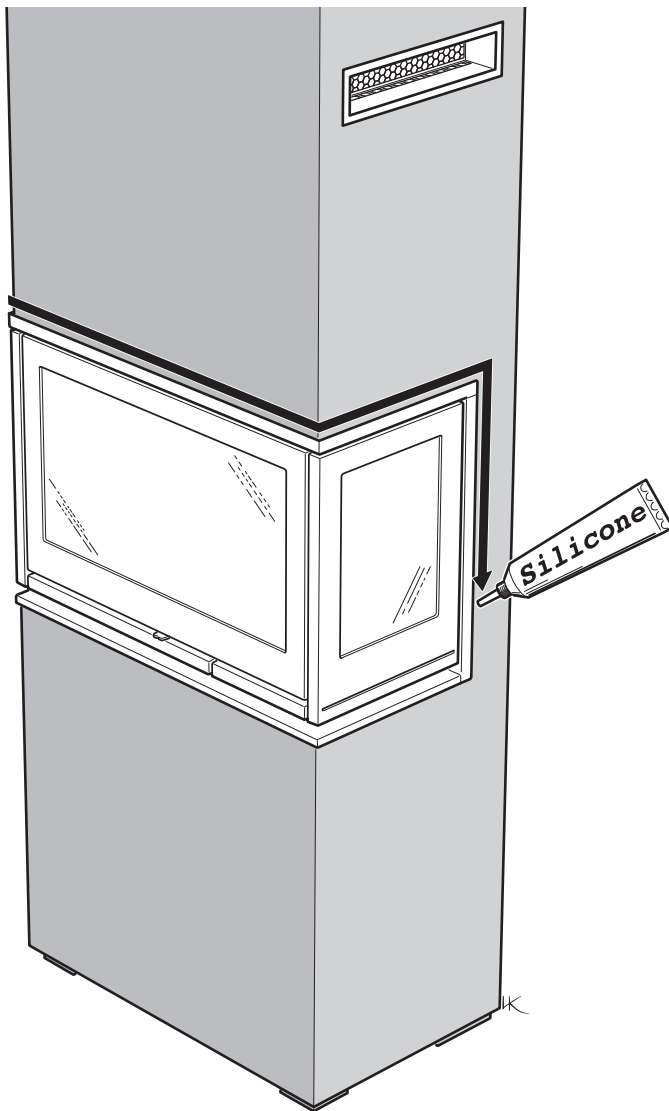

**SE** Contura förbehåller sig rätten att ändra angivna mått och beskrivna förfaranden i denna anvisning utan särskilt meddelande. Den aktuella utgåvan kan laddas ner från [www.contura.eu](http://www.contura.eu)

**DE** Contura behält sich das Recht vor, in diesem Dokument angegebene Abmessungen und beschriebene Vorgehensweisen ohne vorherige Ankündigung zu ändern. Die aktuelle Version dieser Heizinstruktion kann unter [www.contura.eu](http://www.contura.eu) heruntergeladen werden.

**NO** Contura forbeholder seg retten til å endre angitte mål og beskrevet fremgangsmåte i denne anvisningen uten særskilt varsel. Den aktuelle utgaven kan lastes ned fra [www.contura.eu](http://www.contura.eu)

**FR** Contura se réserve le droit de modifier sans notification préalable les mesures et les opérations décrites dans les présentes instructions. La dernière édition peut être téléchargée à partir de notre site [www.contura.eu](http://www.contura.eu)

**GB** Contura reserves the right to change dimensions and procedures described in these instructions at any time without special notice. The current edition can be downloaded from [www.contura.eu](http://www.contura.eu)

**DK** Contura forbeholder sig ret til at ændre de oplyste mål og beskrevne fremgangsmåder i denne vejledning uden særskilt varsel. Den aktuelle udgave kan downloades fra [www.contura.eu](http://www.contura.eu)

**FI** Contura pidättää oikeudet tehdä muutoksia tässä ohjeessa annettuihin mittoihin ja menettelyohjeisiin ilman eri ilmoitusta. Uusimman version voi ladata osoitteesta [www.contura.eu](http://www.contura.eu)

**IT** Contura si riserva il diritto di modificare senza preavviso le dimensioni indicate e le procedure descritte nelle presenti istruzioni. La versione più recente può essere scaricata da [www.contura.eu](http://www.contura.eu)

**NL** Contura behoudt zich het recht voor zonder voorafgaande kennisgeving vermeldde maten en beschreven methoden te wijzigen. De actuele uitgave kan worden gedownload op [www.contura.eu](http://www.contura.eu)

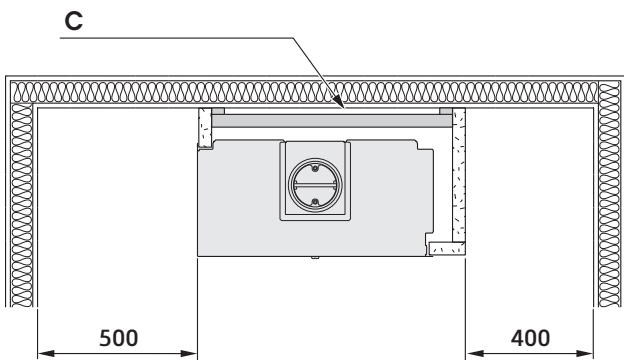
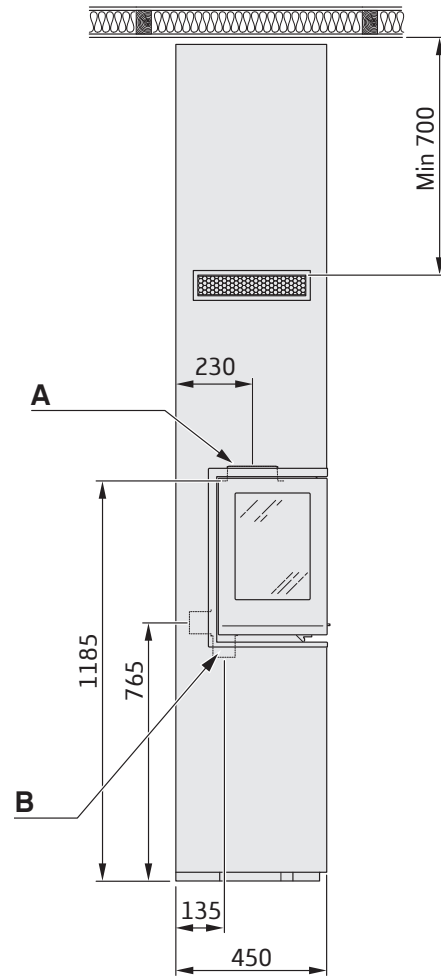
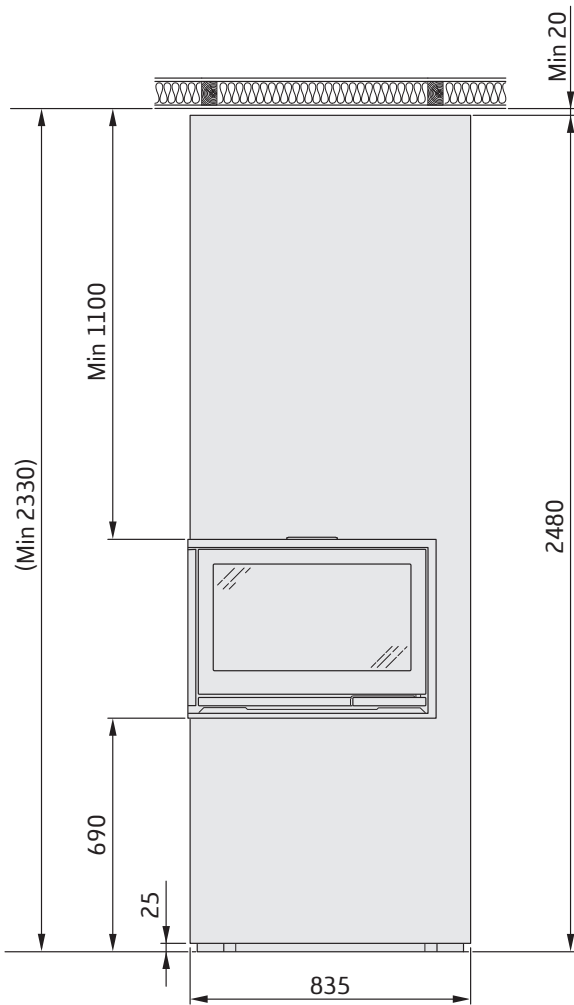

- SE** A. Utv. Ø150 mm  
B. Tilluftsstos Ø65 mm  
C. 20 mm Luftspalt
- DE** A. Außengew. Ø150 mm  
B. Zuluftstutzen Ø65 mm  
C. 20 mm Luftspalt
- NO** A. Utv. Ø150 mm  
B. Tilkobling til forbrenningsluft Ø65 mm  
C. 20 mm Luftspalte
- FR** A. Diam. ext. Ø150 mm  
B. Manchon d'arrivée d'air Ø65 mm  
C. 20 mm lame d'air
- GB** A. Ext. Ø150 mm  
B. Air inlet Ø65 mm  
C. 20 mm Air gap
- DK** A. Udv. Ø150 mm  
B. Friskluftsstuds Ø65 mm  
C. 20 mm Luftspalte
- FI** A. Ulkop. Ø150 mm  
B. Palamisilmaliitäntä Ø65 mm  
C. 20 mm Ilmarako
- IT** A. Esterno Ø150 mm  
B. Boccetta di presa d'aria esterna Ø65 mm  
C. 20 mm di spazio libero
- NL** A. Buitendiam. Ø150 mm  
B. Toevoerluchtaansluiting Ø65 mm  
C. 20 mm Luchtspleet



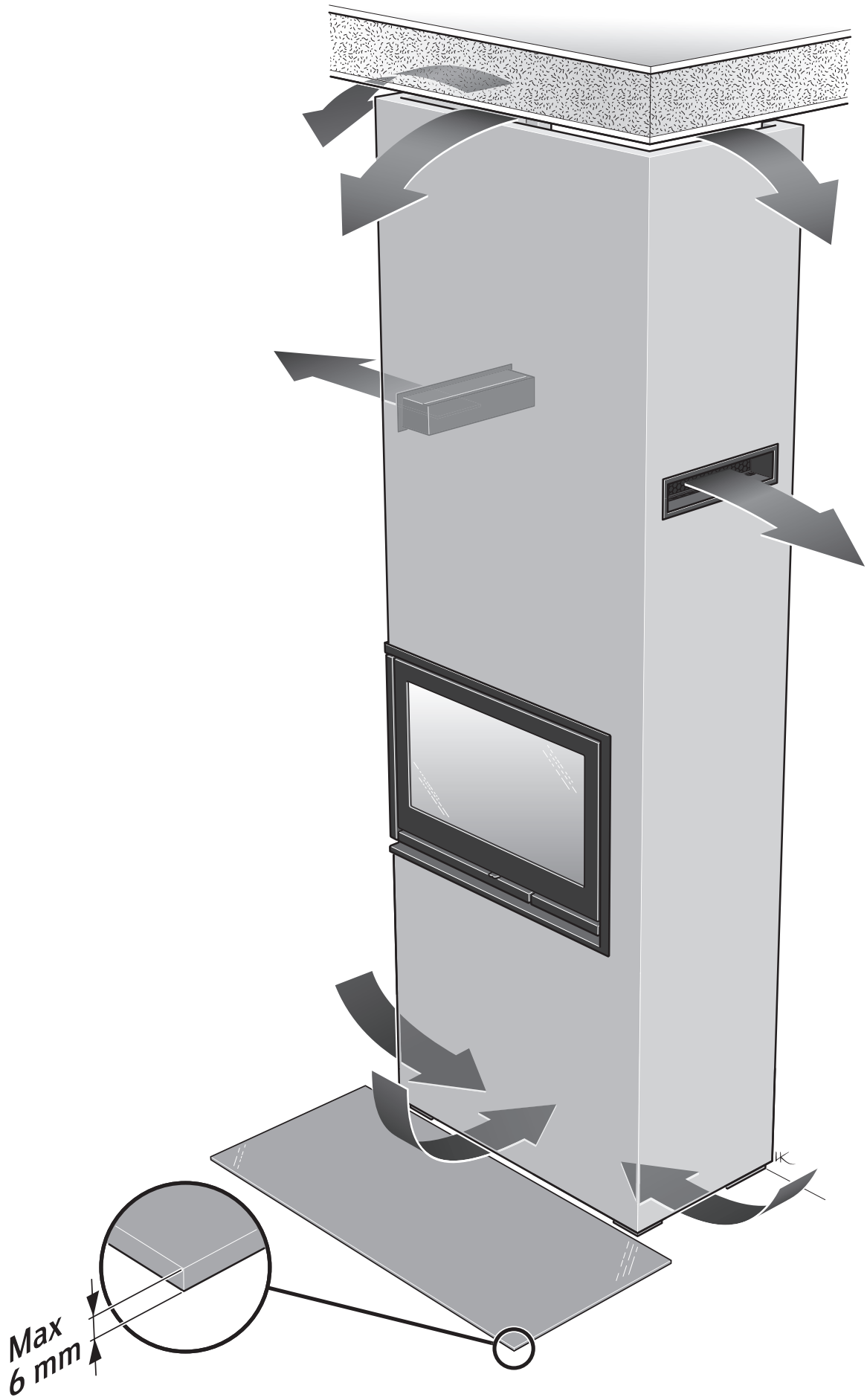



1

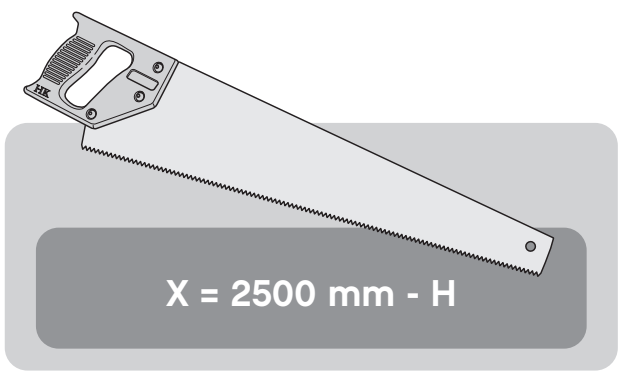
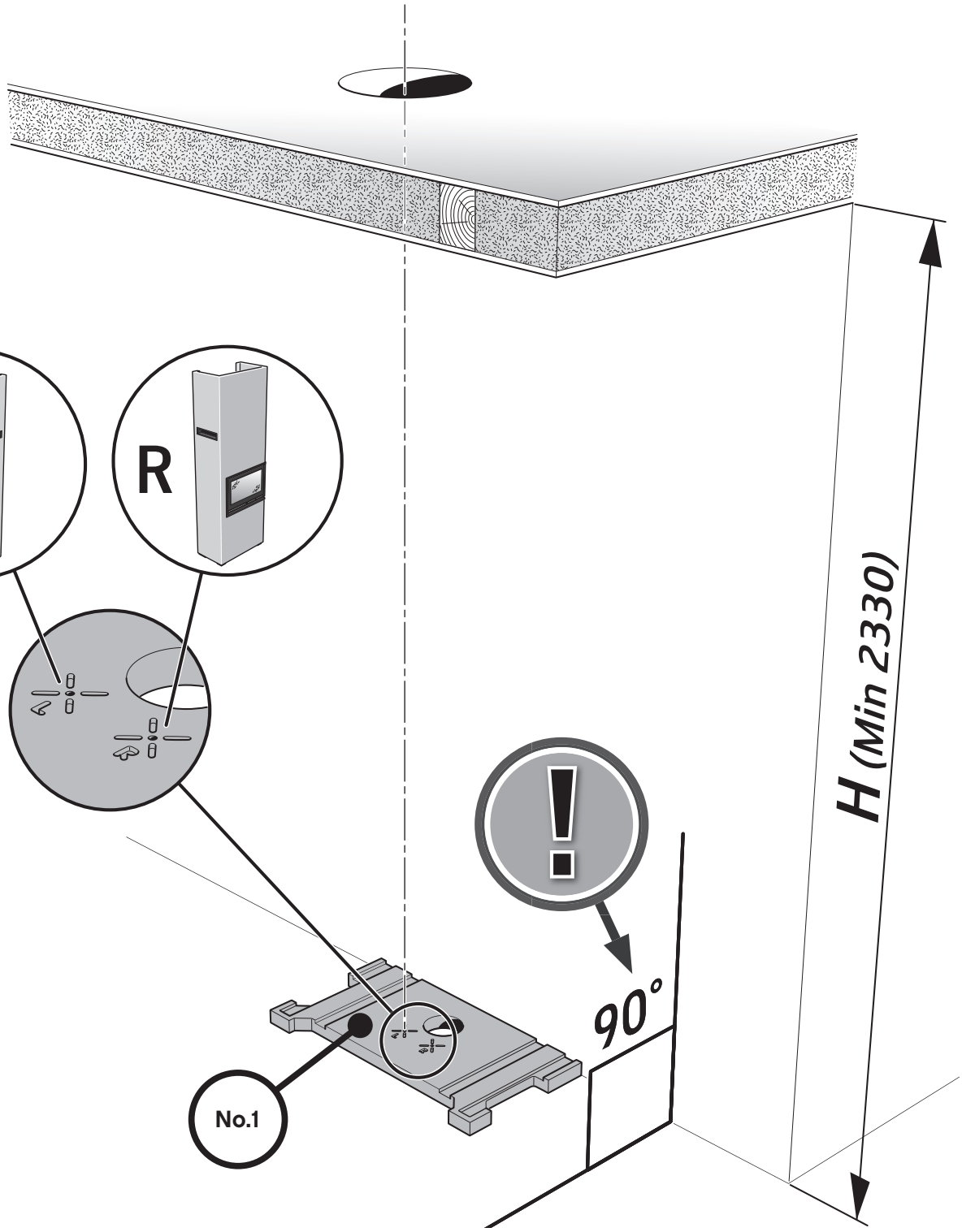

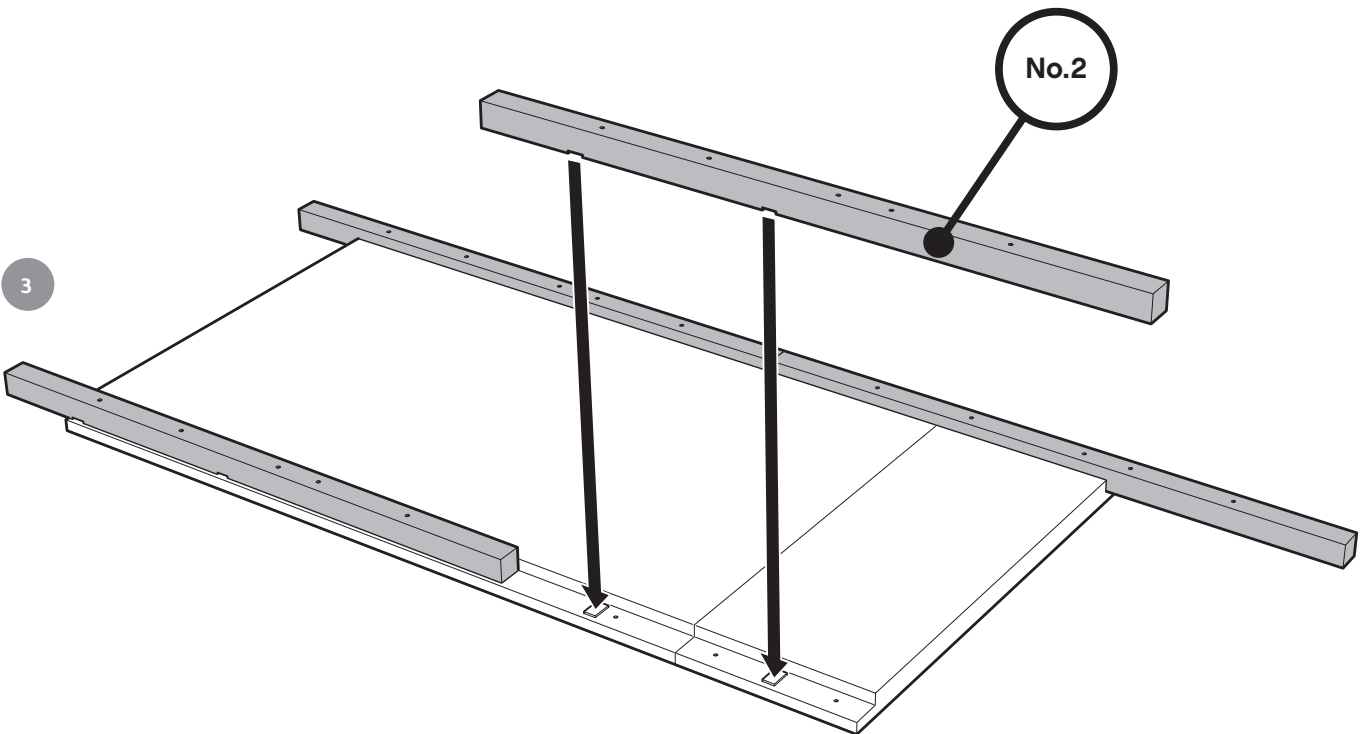
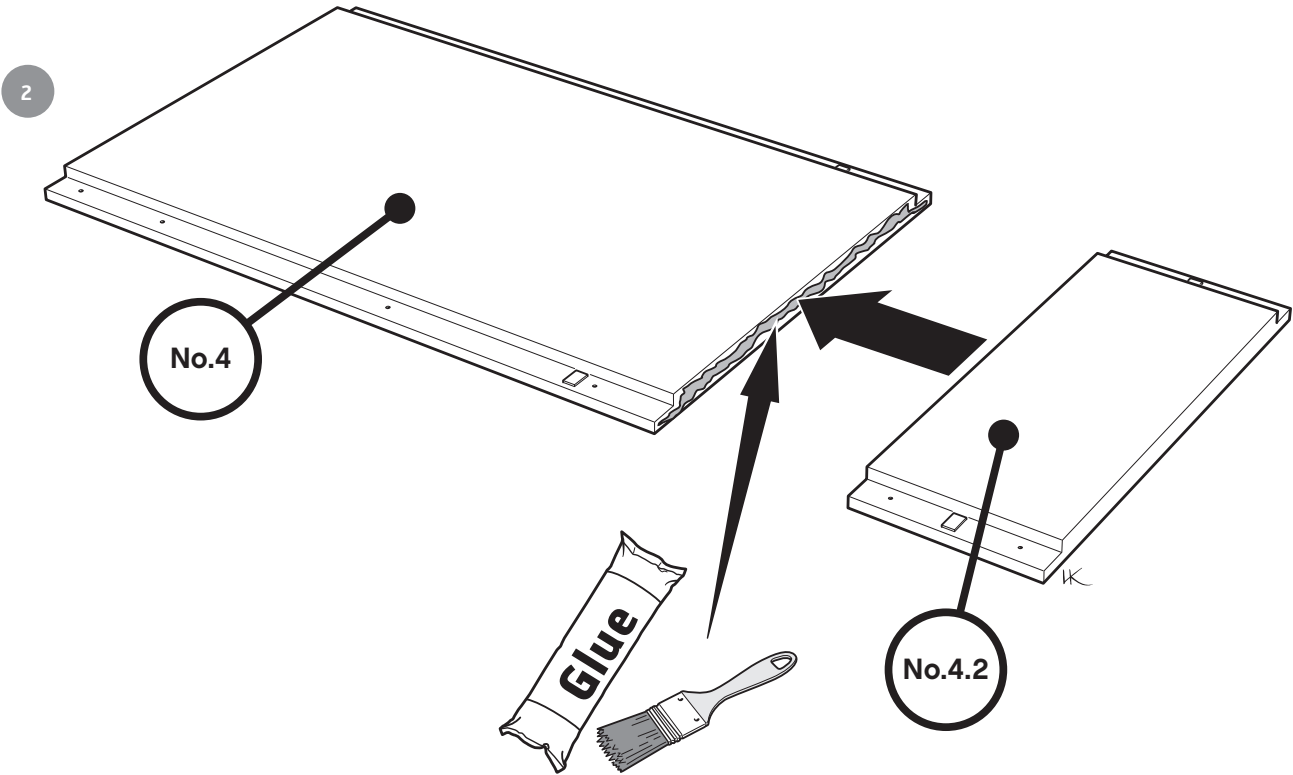



4

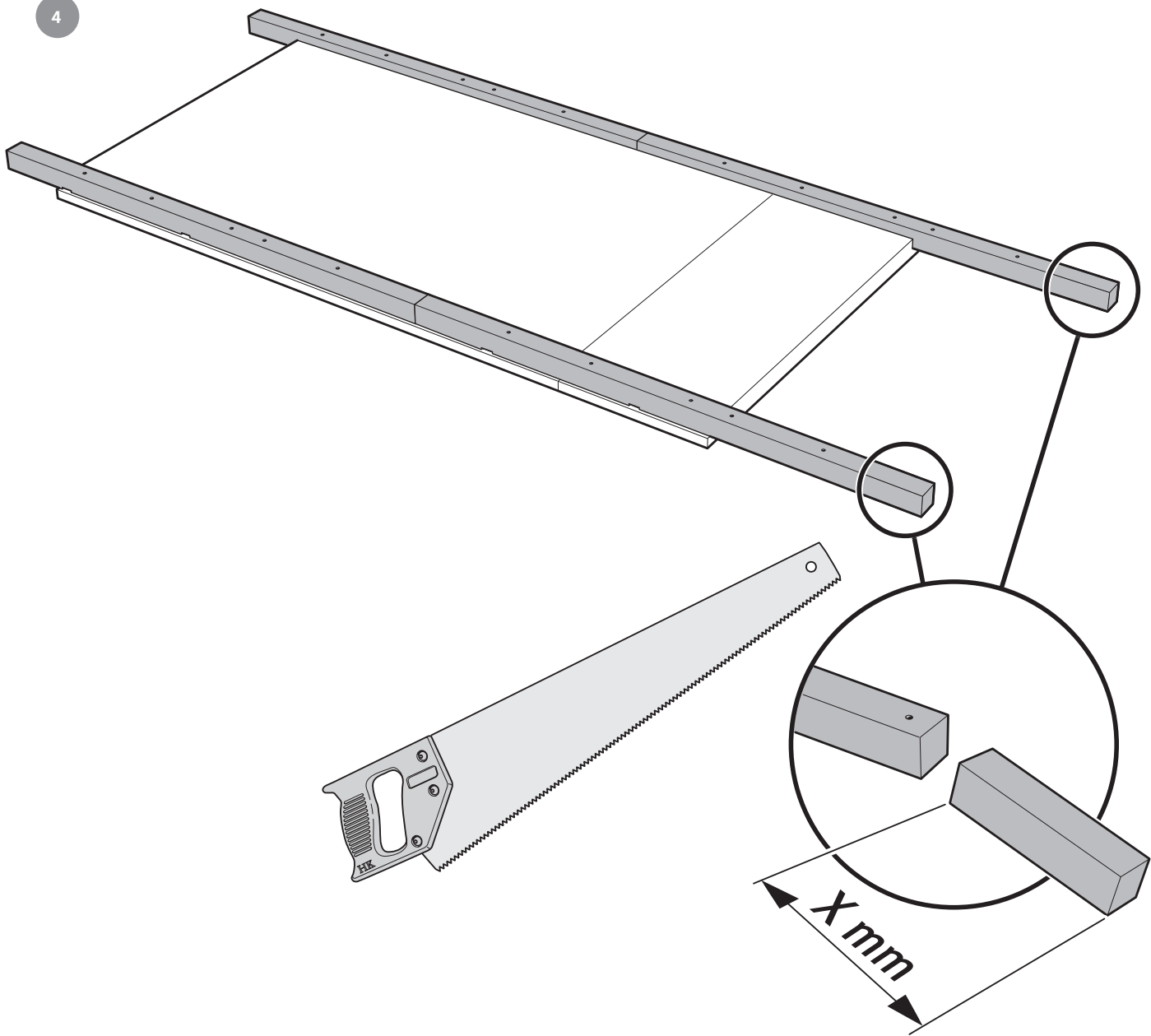

$X = 2500 \text{ mm} - H$

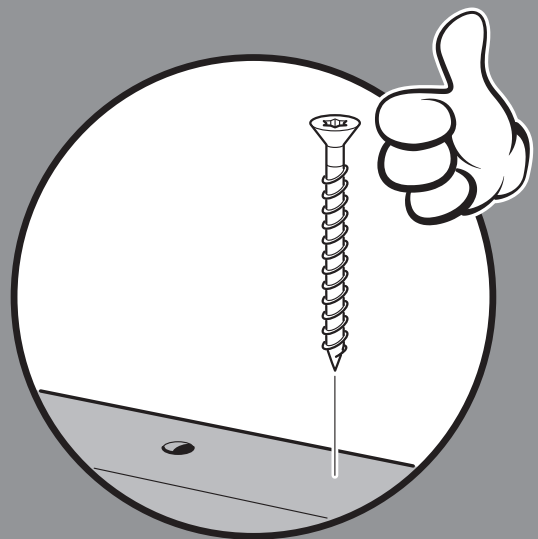
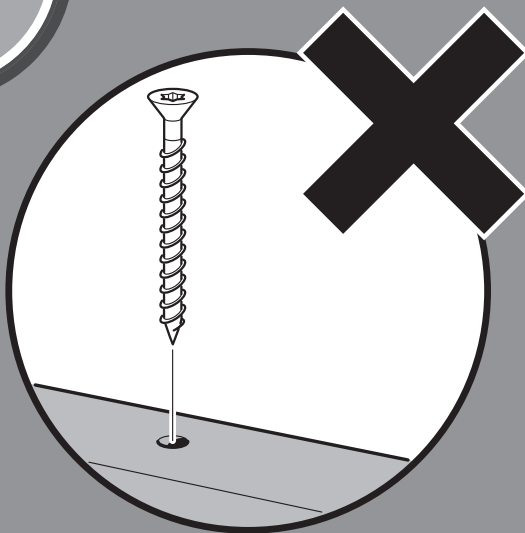
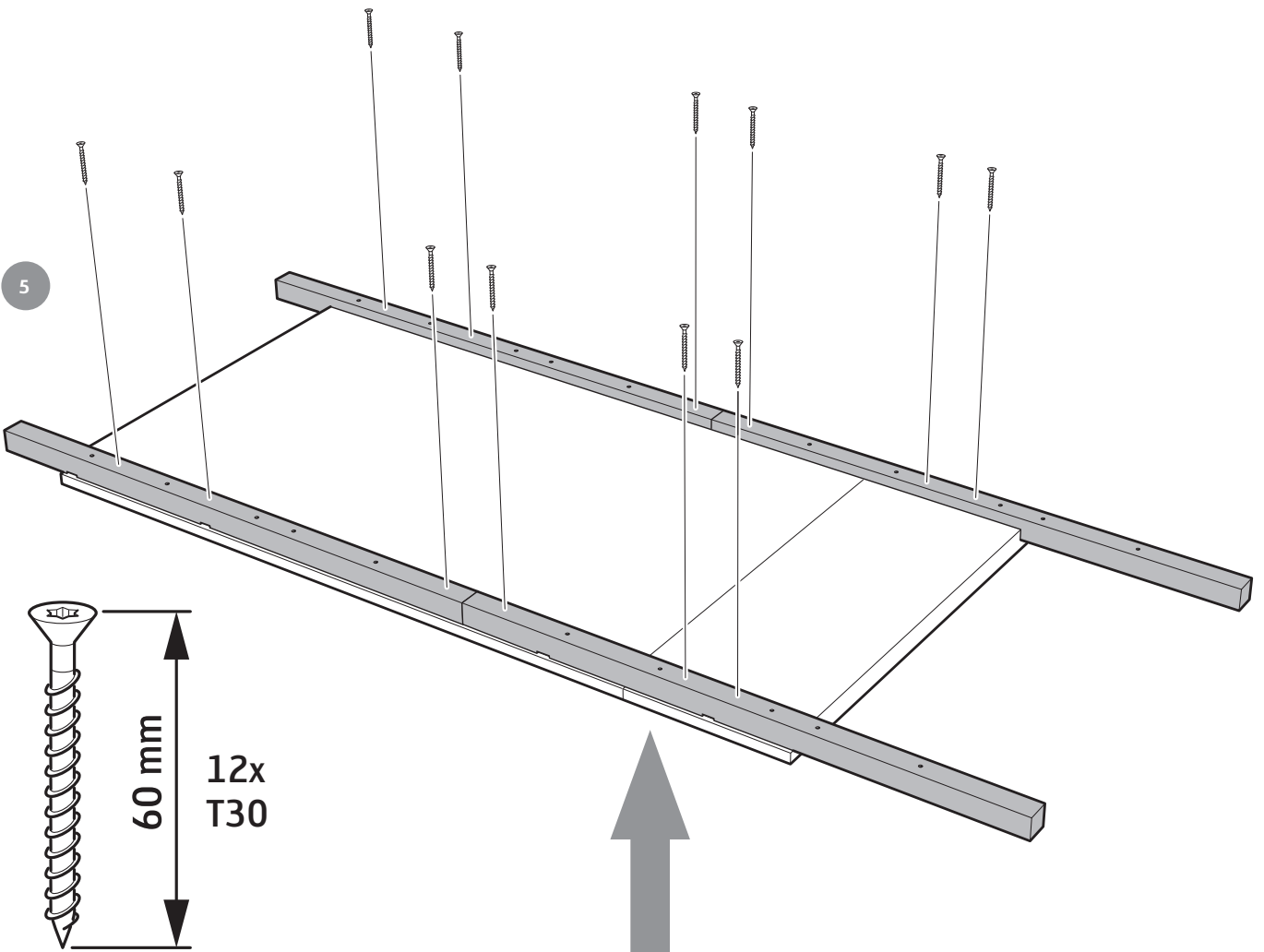



6

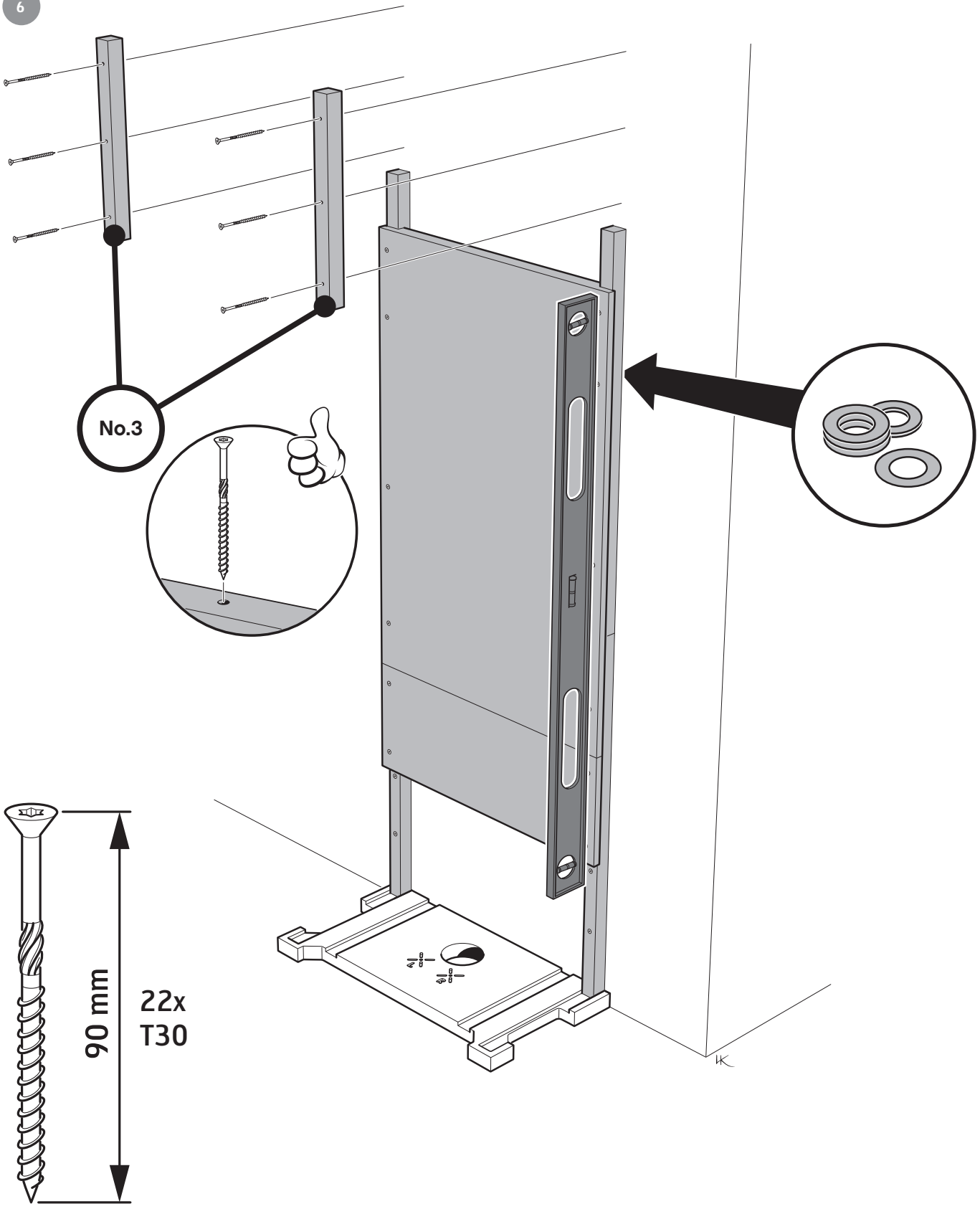

No.3

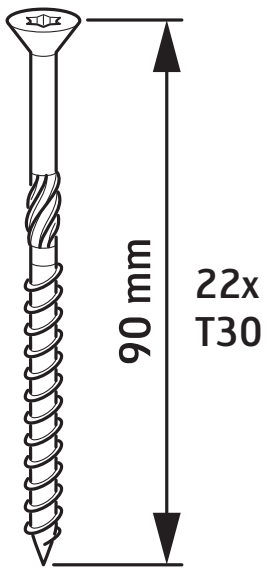
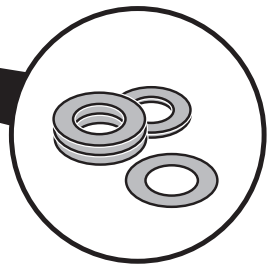
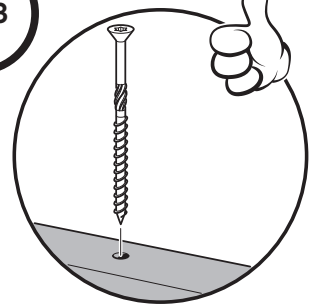





7

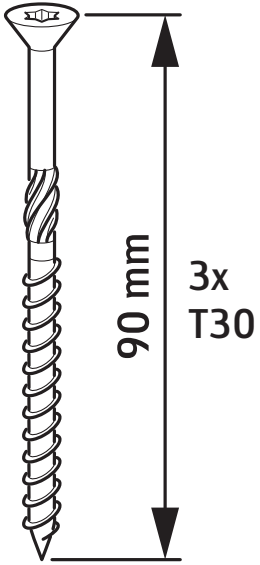

No.5

No.5.2

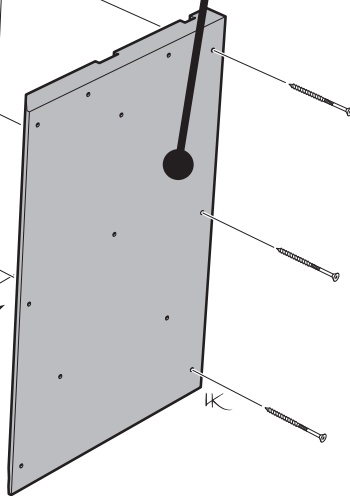
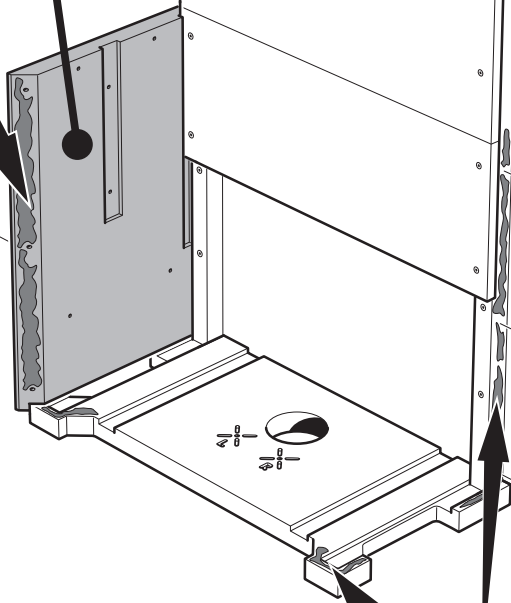
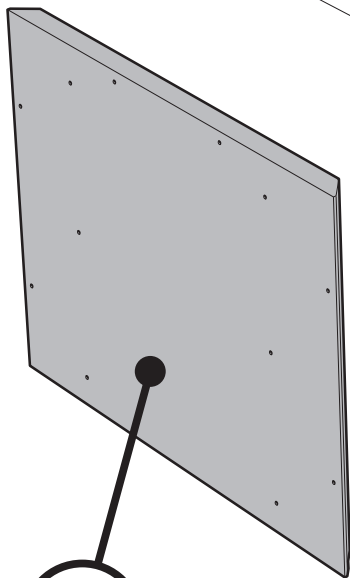



8

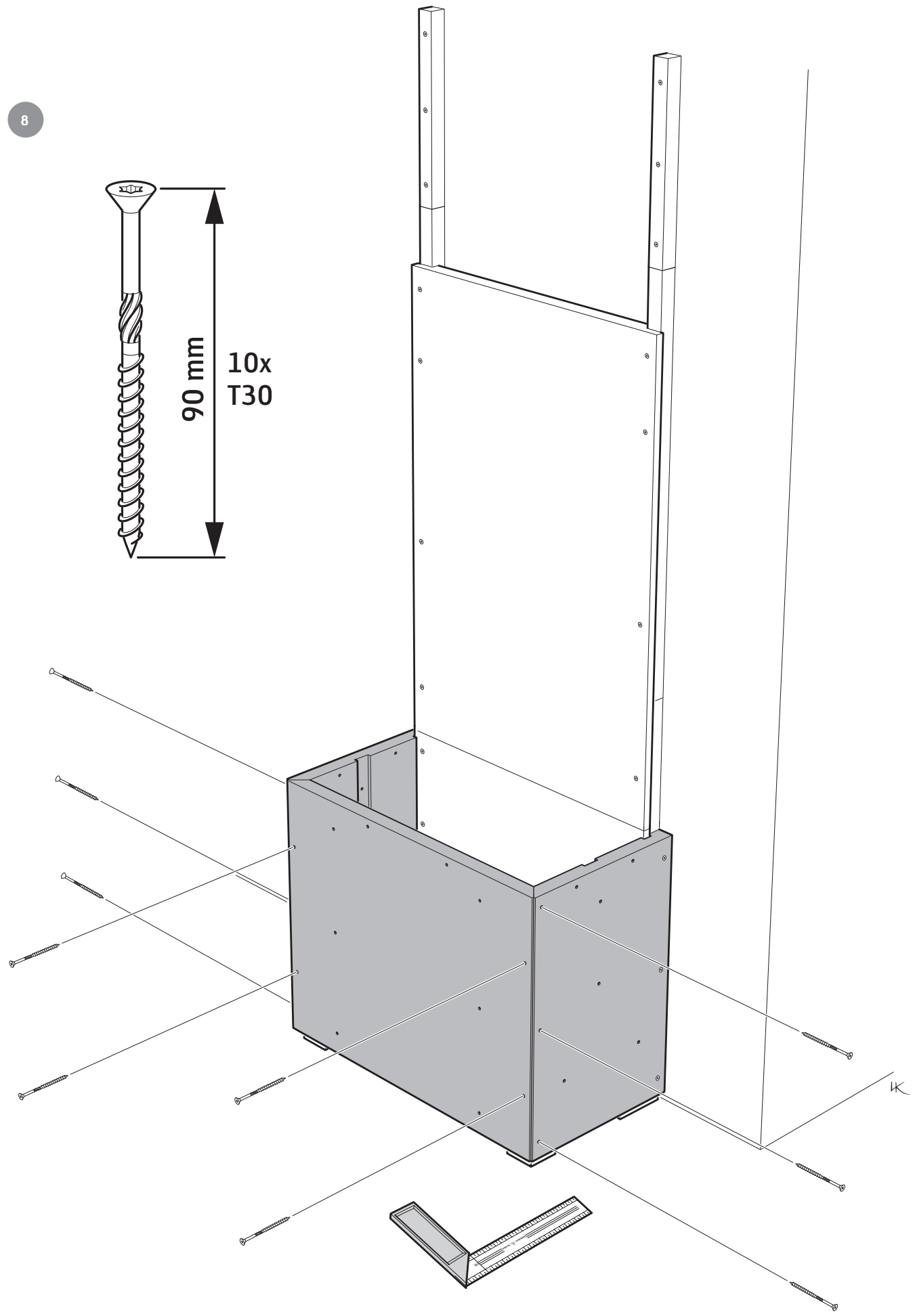
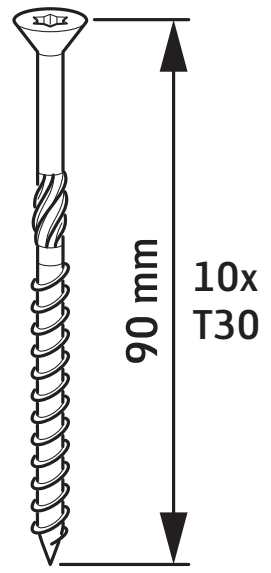



9

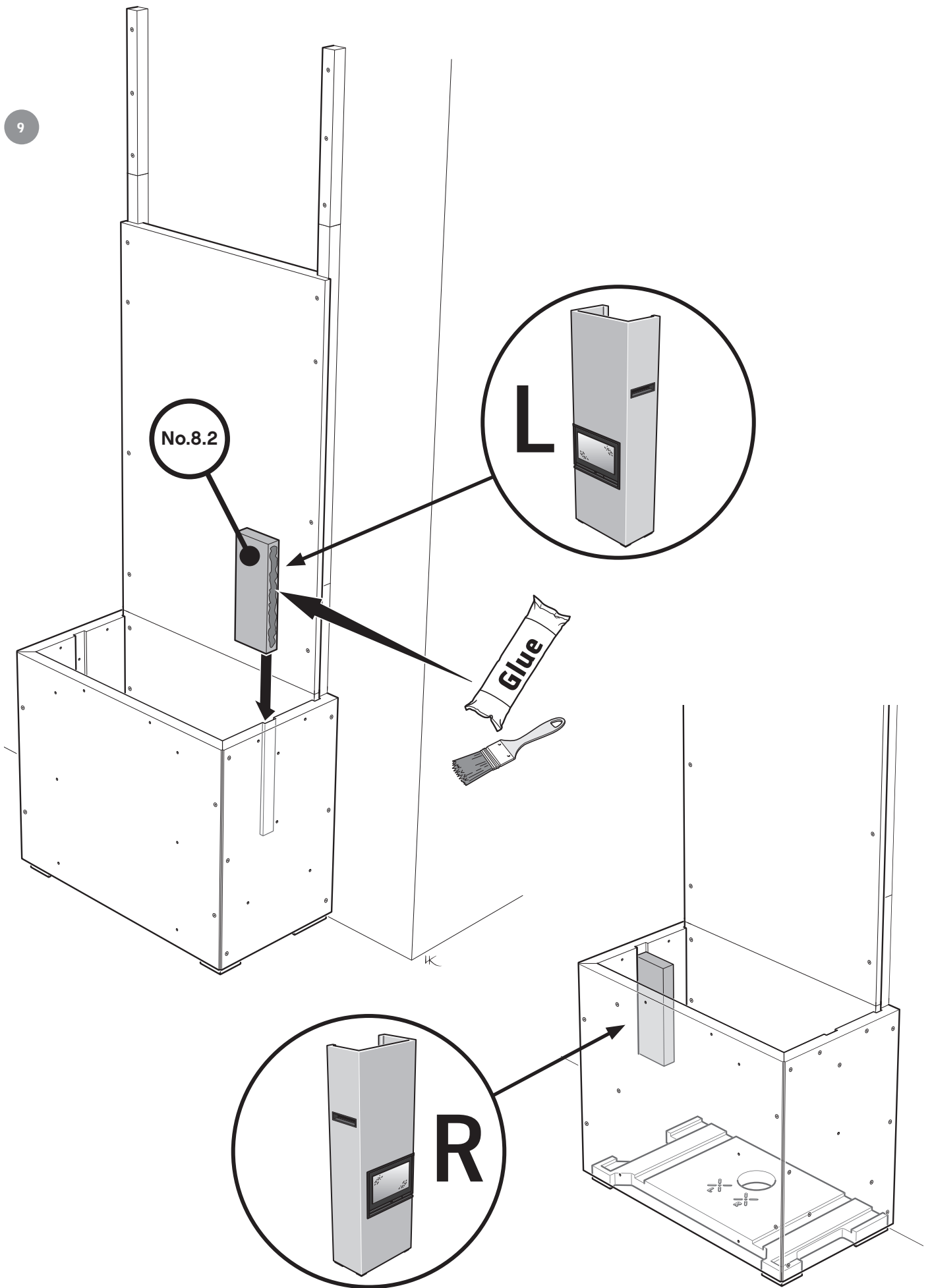



10

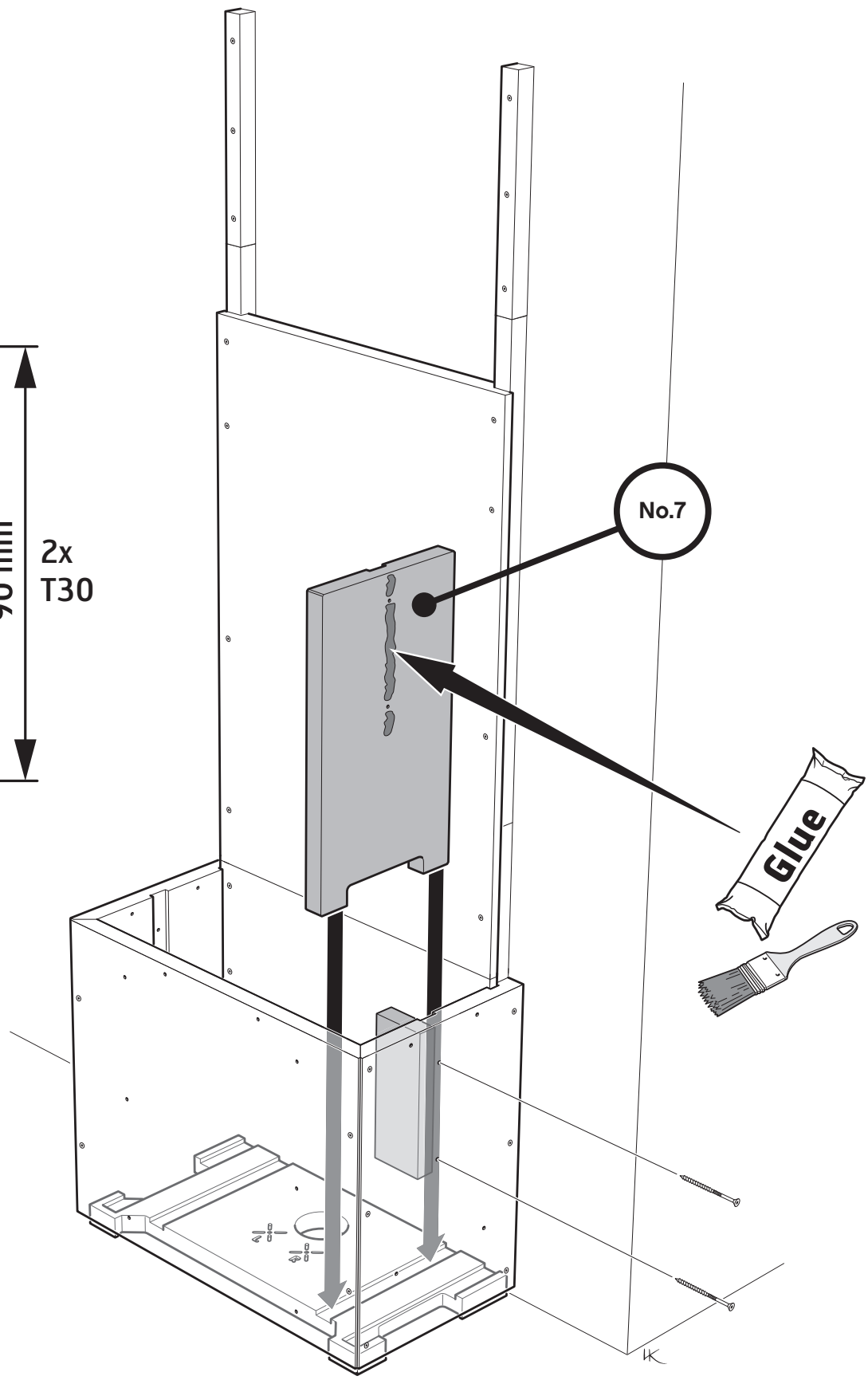
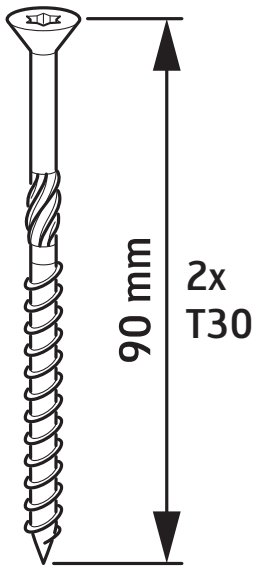



11

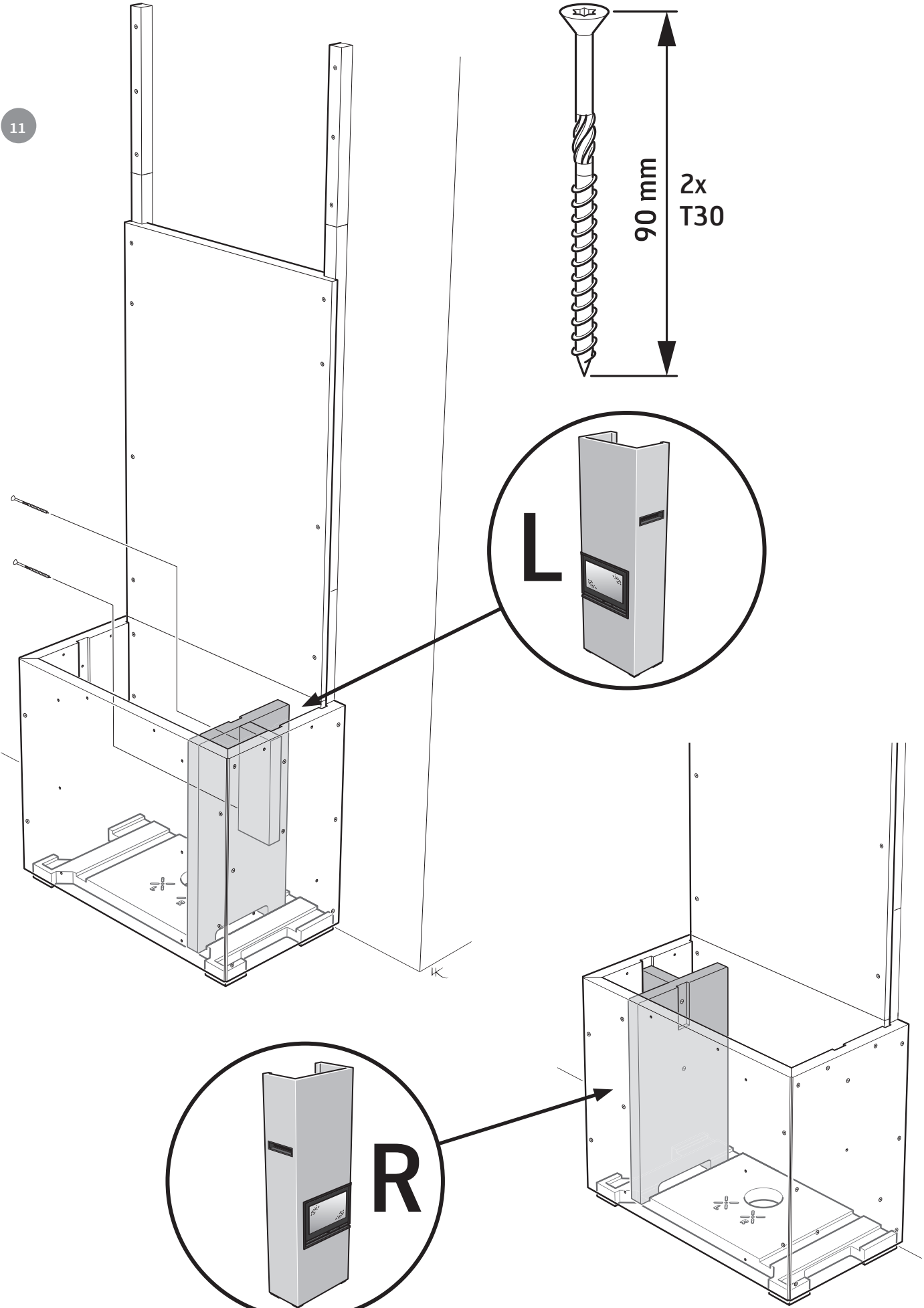
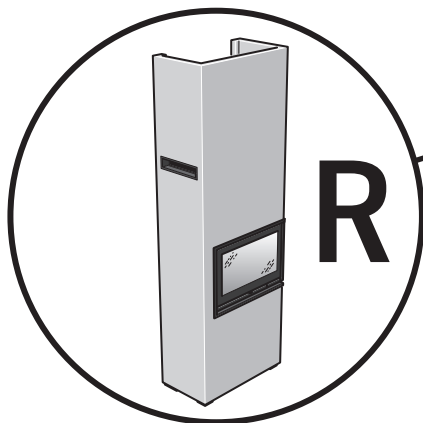
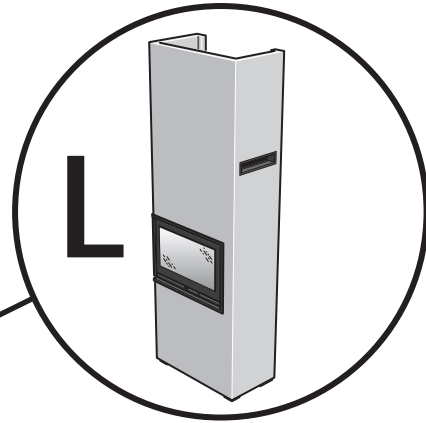
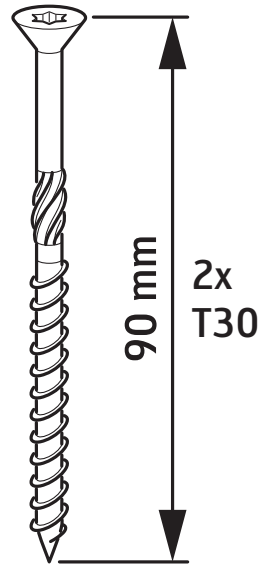



12

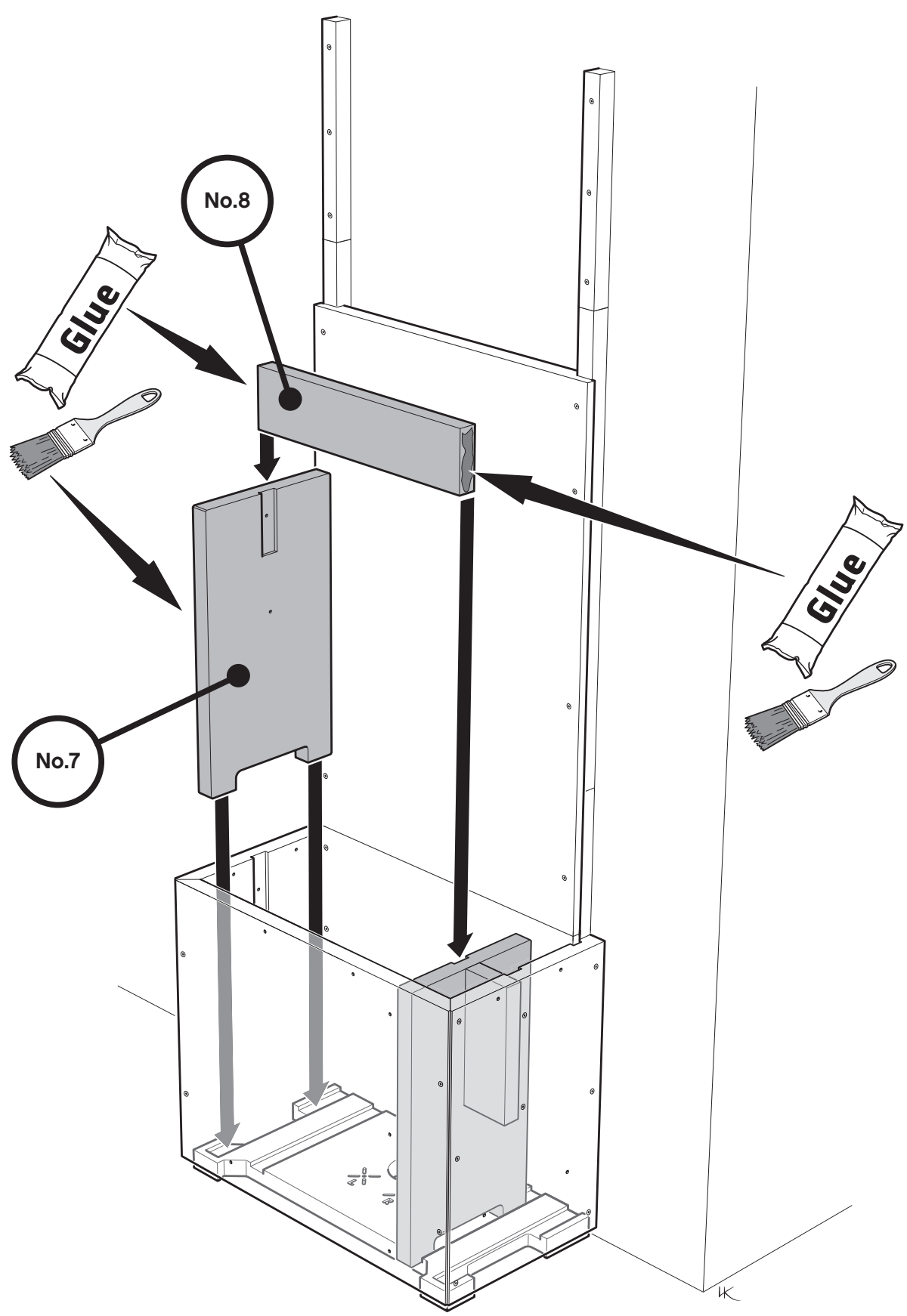



13

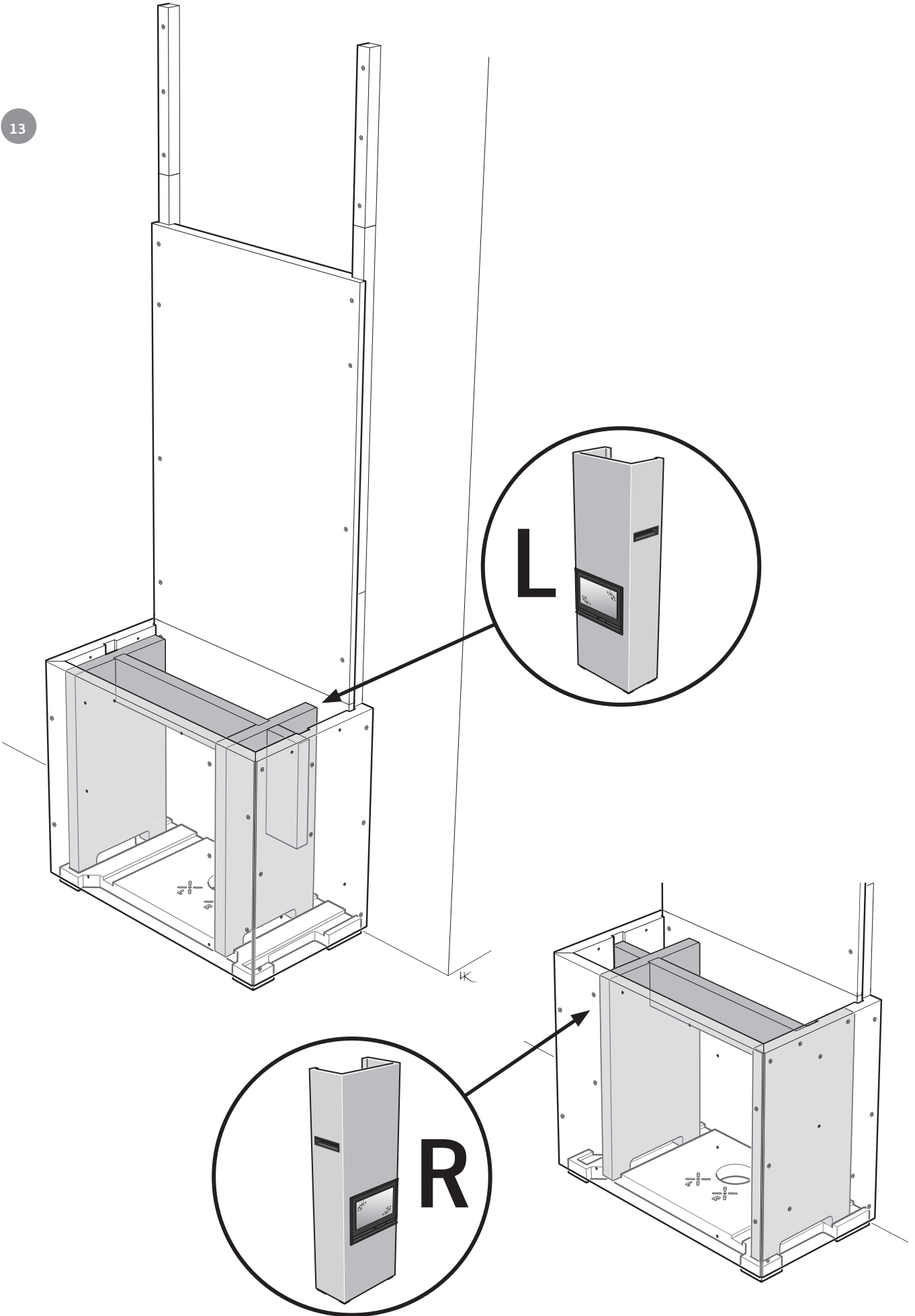



14

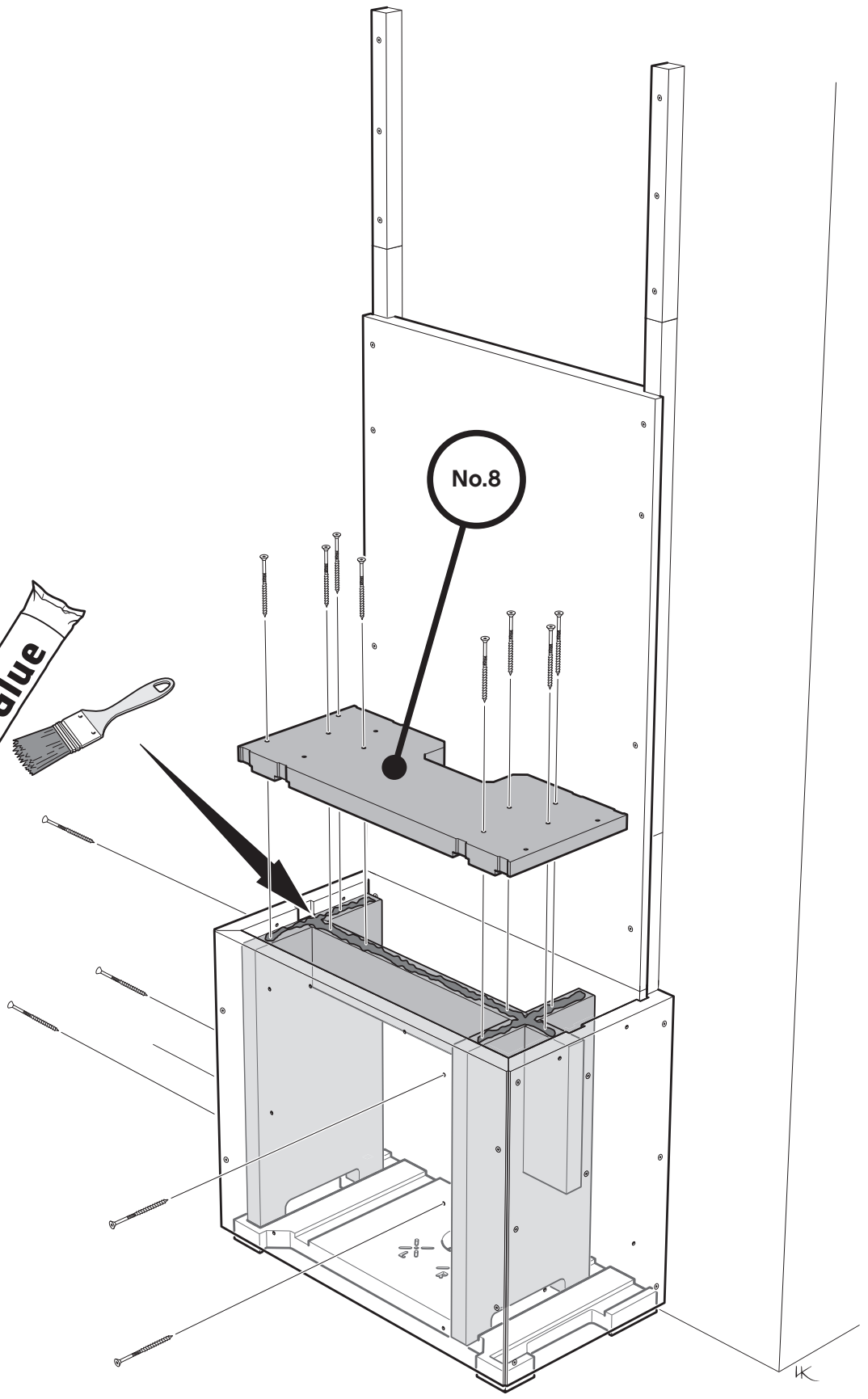
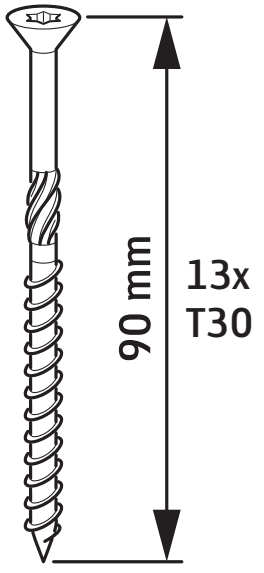





15

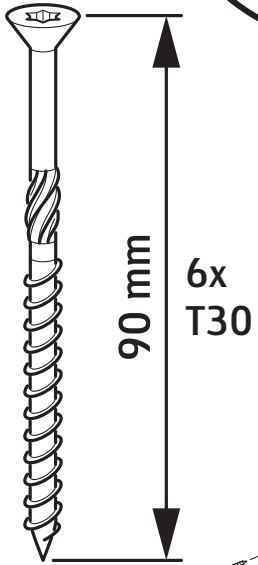
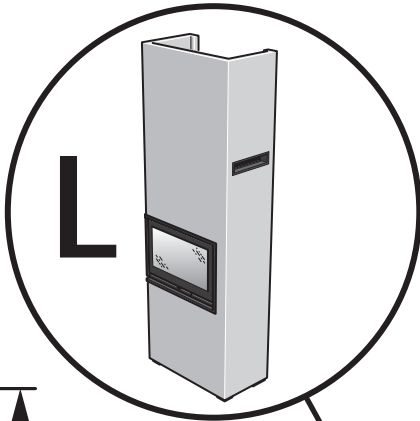

90 mm  
6x  
T30

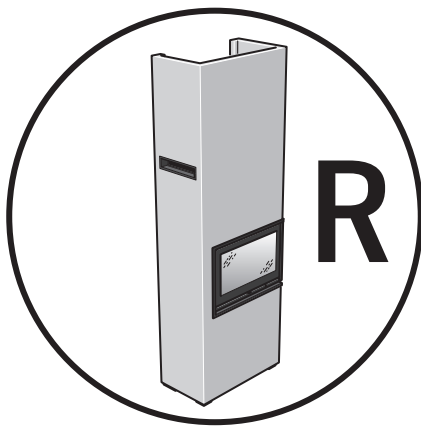
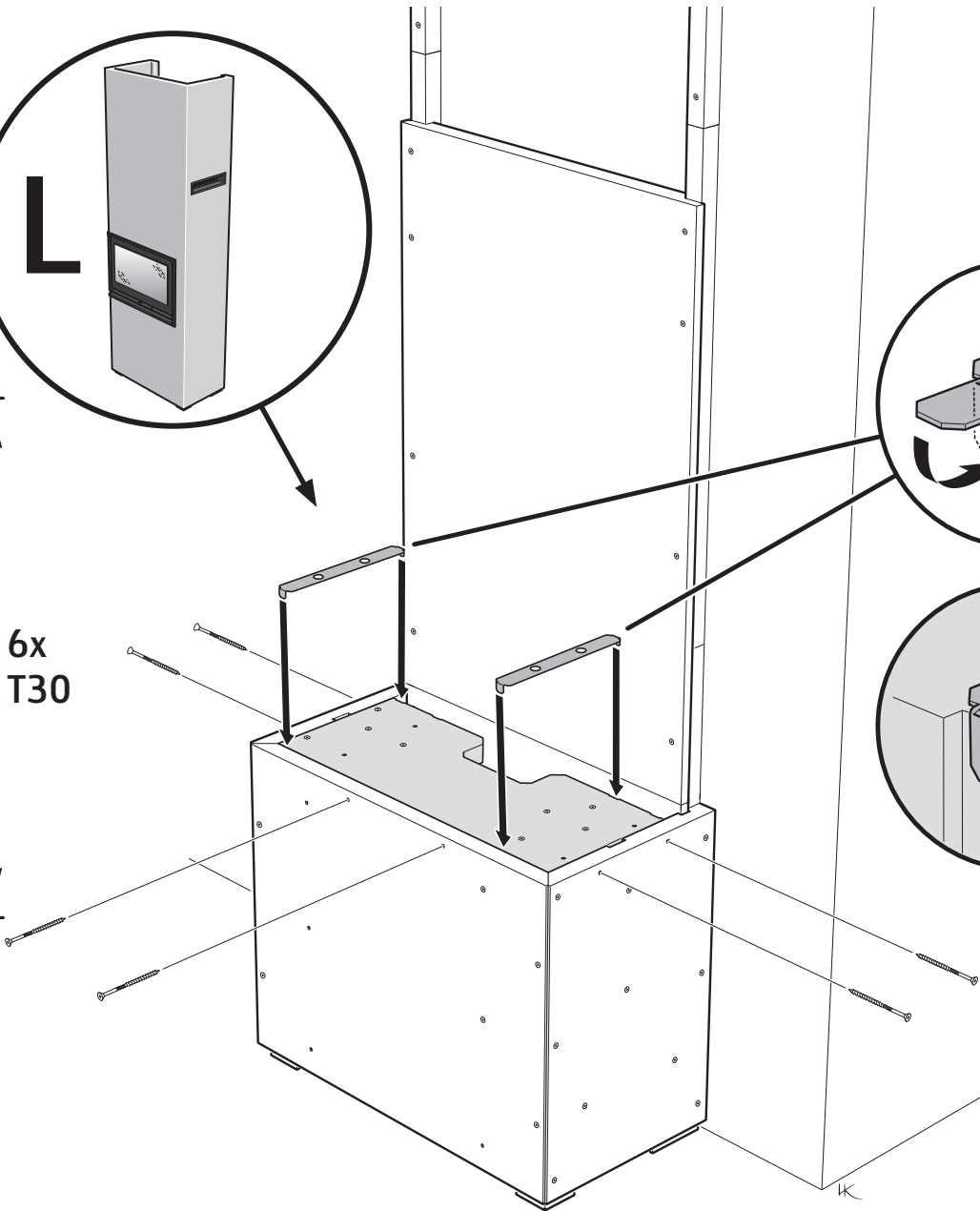

R

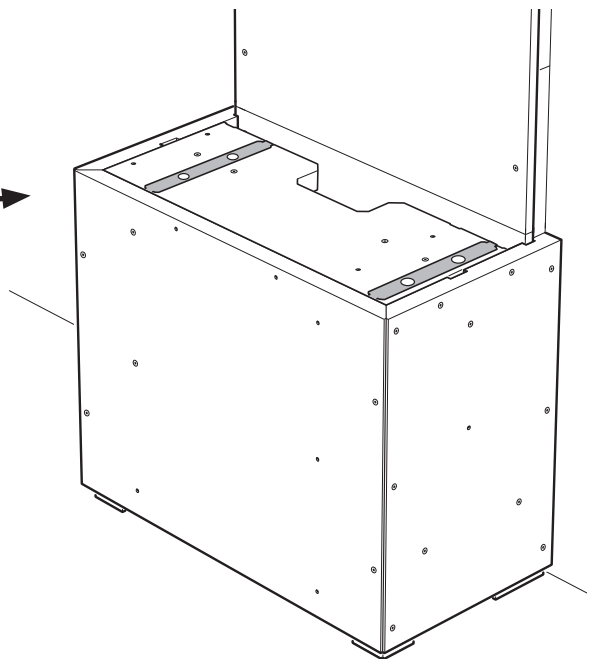



16

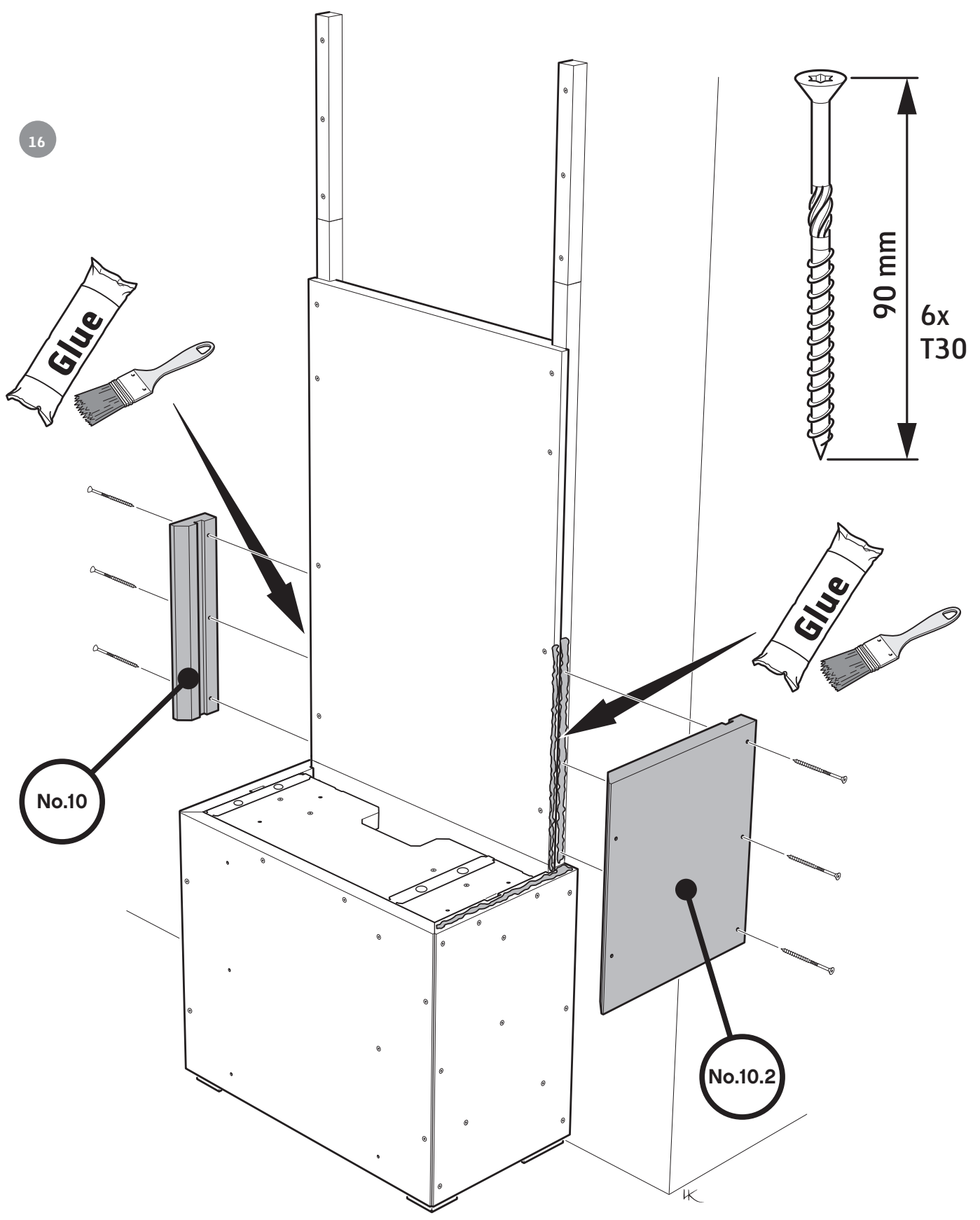



17

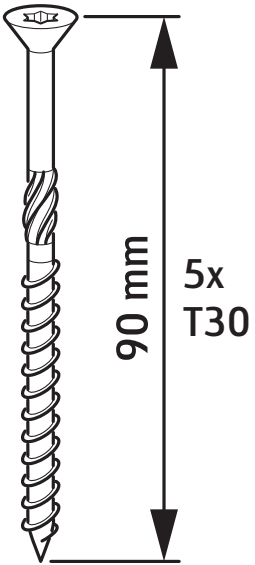
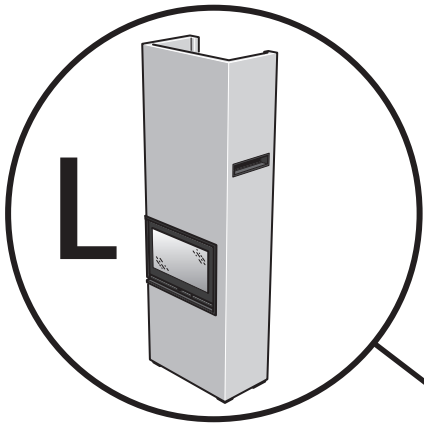

No.10.3

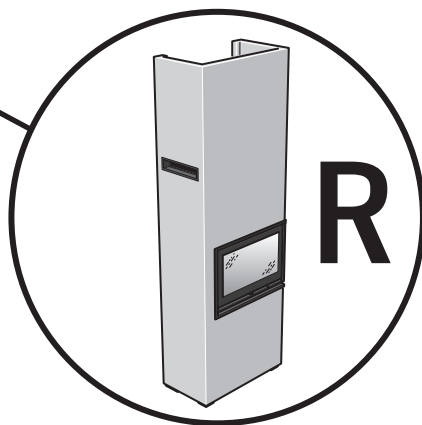
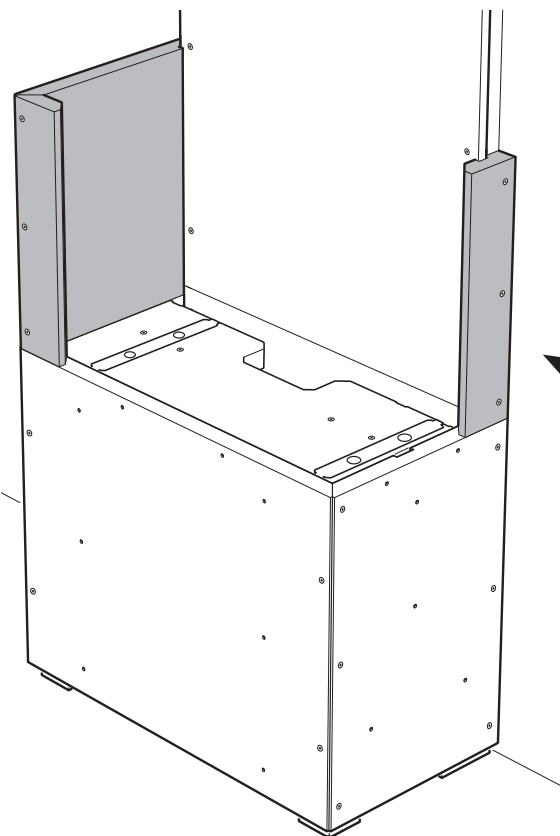
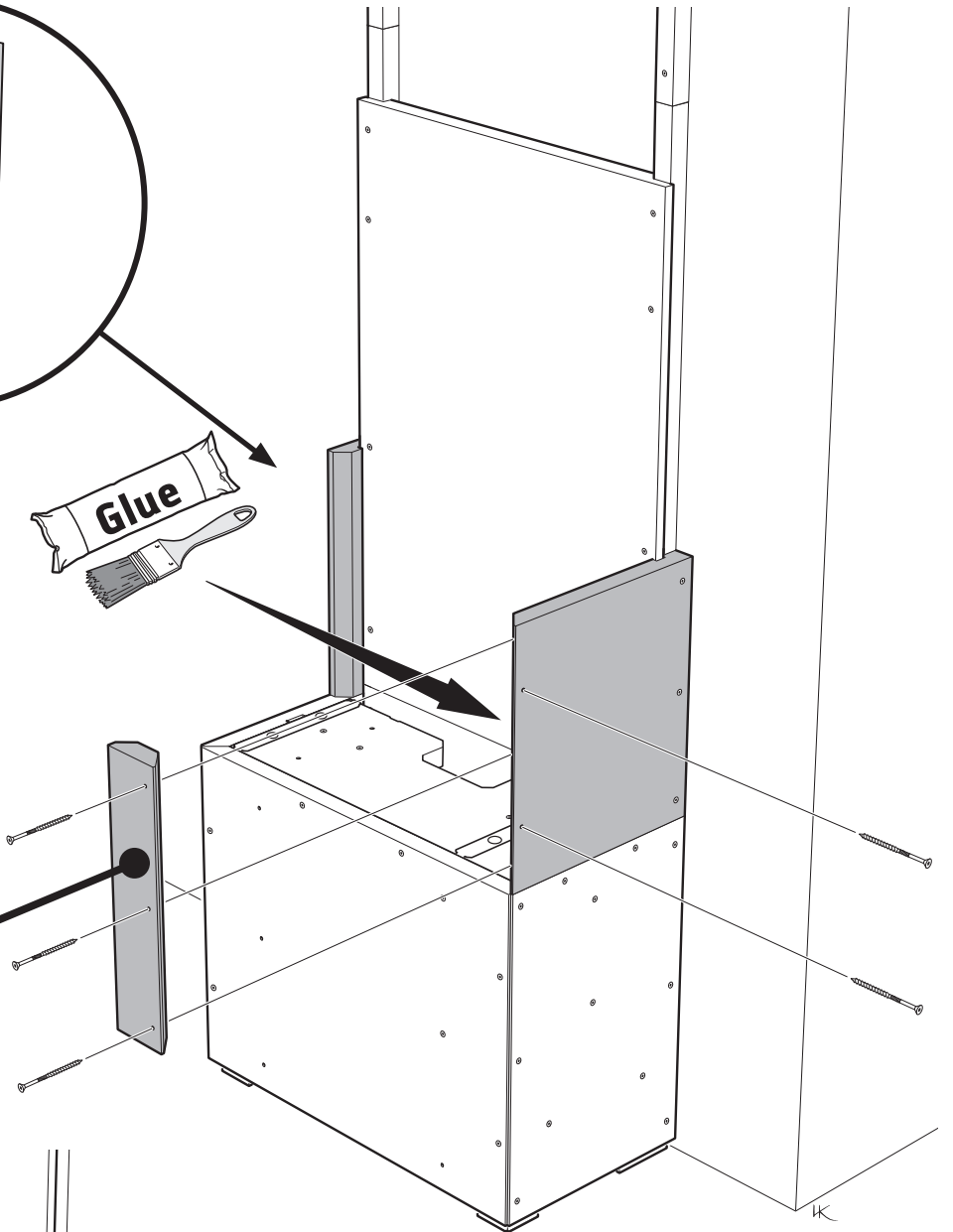



18

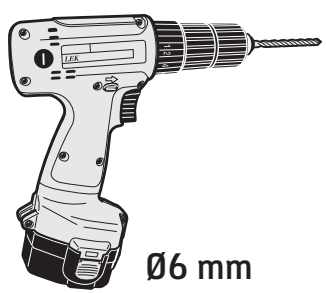
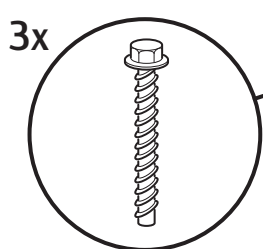

Ø6 mm

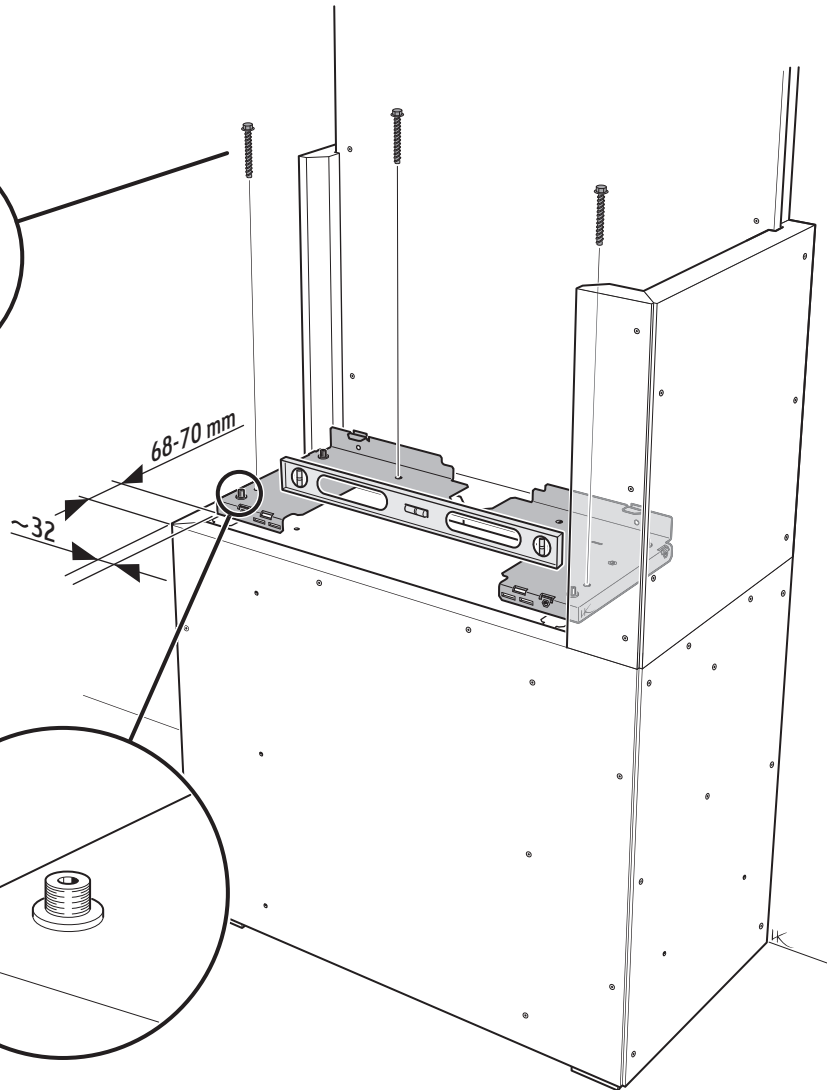
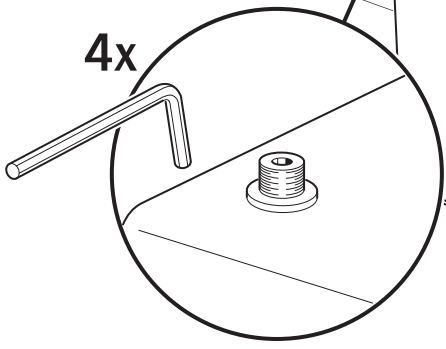



SE

**Alternativ monteringsföljd**

För att underlätta spackling och slipning kring kassetts ram kan detta göras innan kassetten monteras och ansluts. Kassettmontaget utförs i detta fall efter Moment 24. När hela omramningen är monterad färdigställs spackling.

DE

**Alternative Einbaureihenfolge**

Für ein leichteres Spachteln und Schleifen um den Rahmen der Kassette können diese Arbeiten vor Einbau und Anschluss der Kassette erfolgen. Der Einbau der Kassette wird in diesem Fall nach Arbeitsschritt 24 ausgeführt. Die Spachtelarbeiten werden nach dem abschließenden Einbau der Verkleidung fertiggestellt.

NO

**Alternativ monteringsrækkefølge**

For å gjøre det enklere å sparkle og slippe rundt kassettrammen kan dette gjøres før kassetten monteres og tilkobles. Monteringen av kassetten utføres i så fall etter moment 24. Når hele omramningen er montert, ferdigstilles sparklingen.

GB

**Alternative assembly sequence**

It is easier to do filling and sanding work around the cassette frame before the cassette is installed and connected. In this case, the cassette is installed after Step 24. Complete the filling work after the entire surround has been installed.

DK

**Alternativ monteringsrækkefølge**

For at lette spartling og slipning omkring kassetts ramme kan dette foretages, før kassetten monteres og tilsluttes. Kassettmontagen udføres i dette tilfælde efter Punkt 24. Når hele omramningen er monteret, spartles der færdigt.

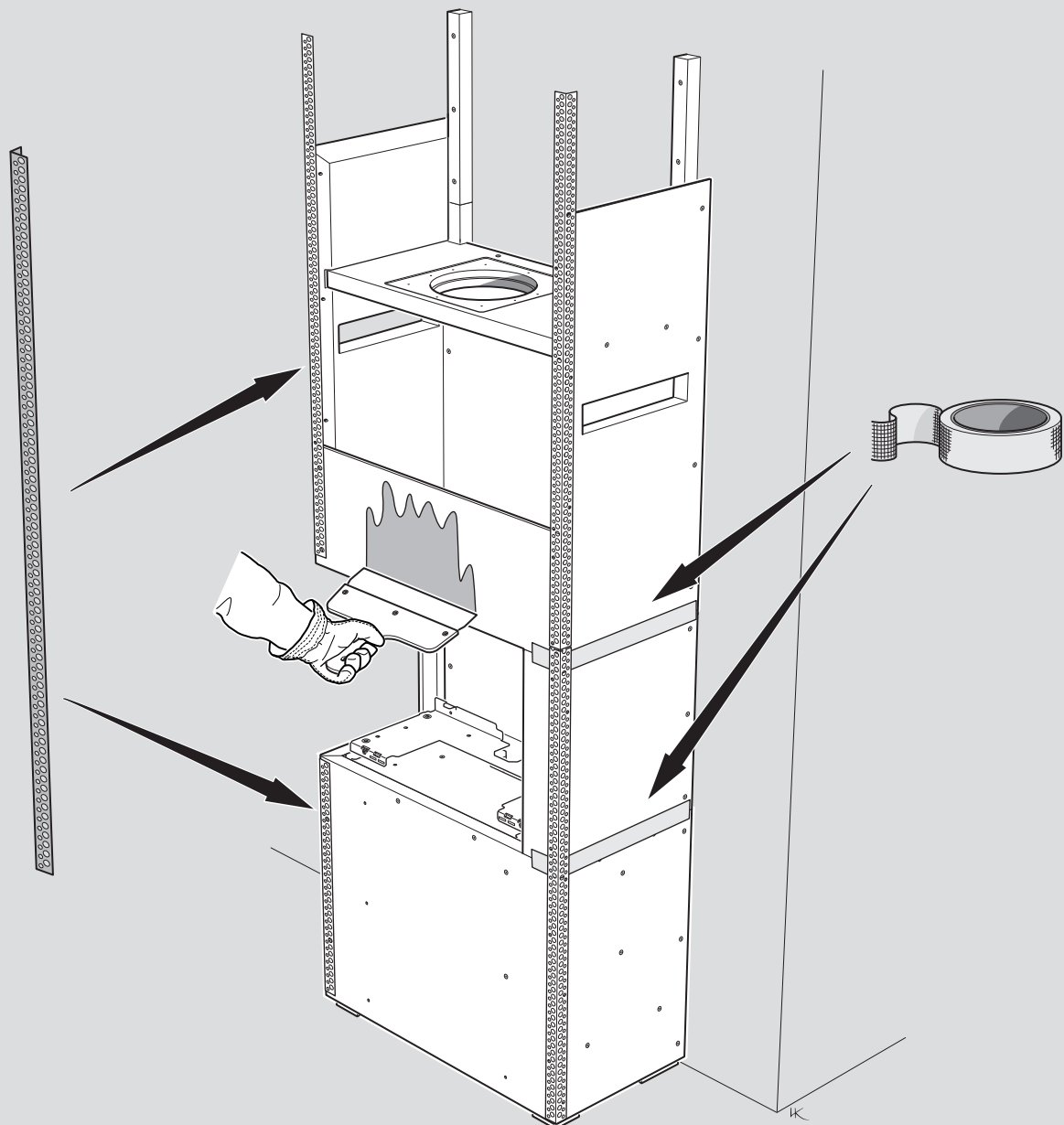

**FR** Séquence de montage alternative  
Effectuer la pose de joints mastic et le ponçage autour du cadre de l'insert, avant de monter et de raccorder ce dernier, pour plus de facilité. Le montage de l'insert est dans ce cas effectué après le point 24. Lorsque l'habillage est en place, terminer la pose de joints mastic.

**FI** Vaihtoehtoinen asennusjärjestys  
Takkasydämen kehysten ympäristön kittaamisen ja hionnan helpottamiseksi sen voi tehdä ennen takkasydämen asennusta ja liittämistä. Takkasydän asennetaan siinä tapauksessa vaiheen 24 mukaan. Kittausta suoritetaan loppuun, kun koko kuori on asennettu.

**IT** Sequenza alternativa di montaggio  
Per facilitare la stuccatura e la levigatura del telaio dell'inserto, è possibile effettuare queste operazioni prima che l'inserto sia montato e collegato. In questo caso, il montaggio dell'inserto sarà fatto dopo il Passo 24. Quando tutto il telaio è montato, si completa la stuccatura.

**NL** Alternatieve montagevolgorde  
Om het voegen en schuren rond de omlijsting van de inzethaard te vergemakkelijken, kan dat worden gedaan vóór de montage en aansluiting van de inzethaard. De montage van de inzethaard wordt dan uitgevoerd na stap 24. Als de volledige omlijsting gemonteerd, wordt deze verder afgevoegd.

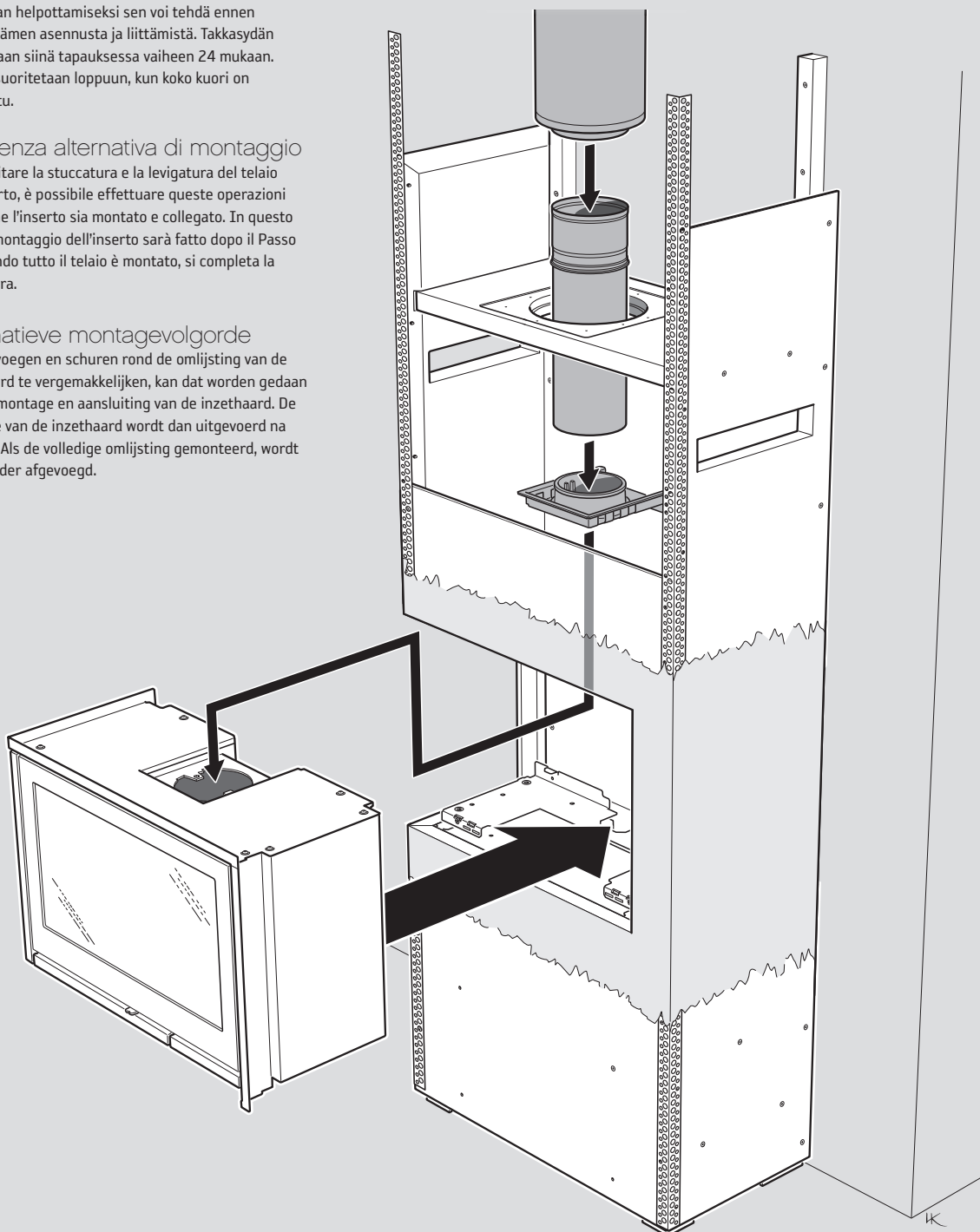



19

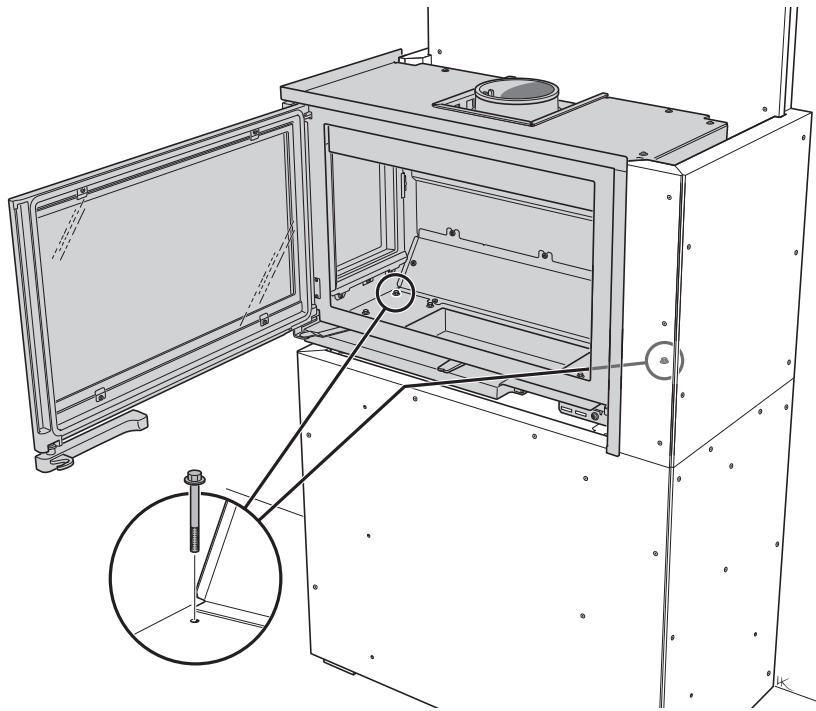

20

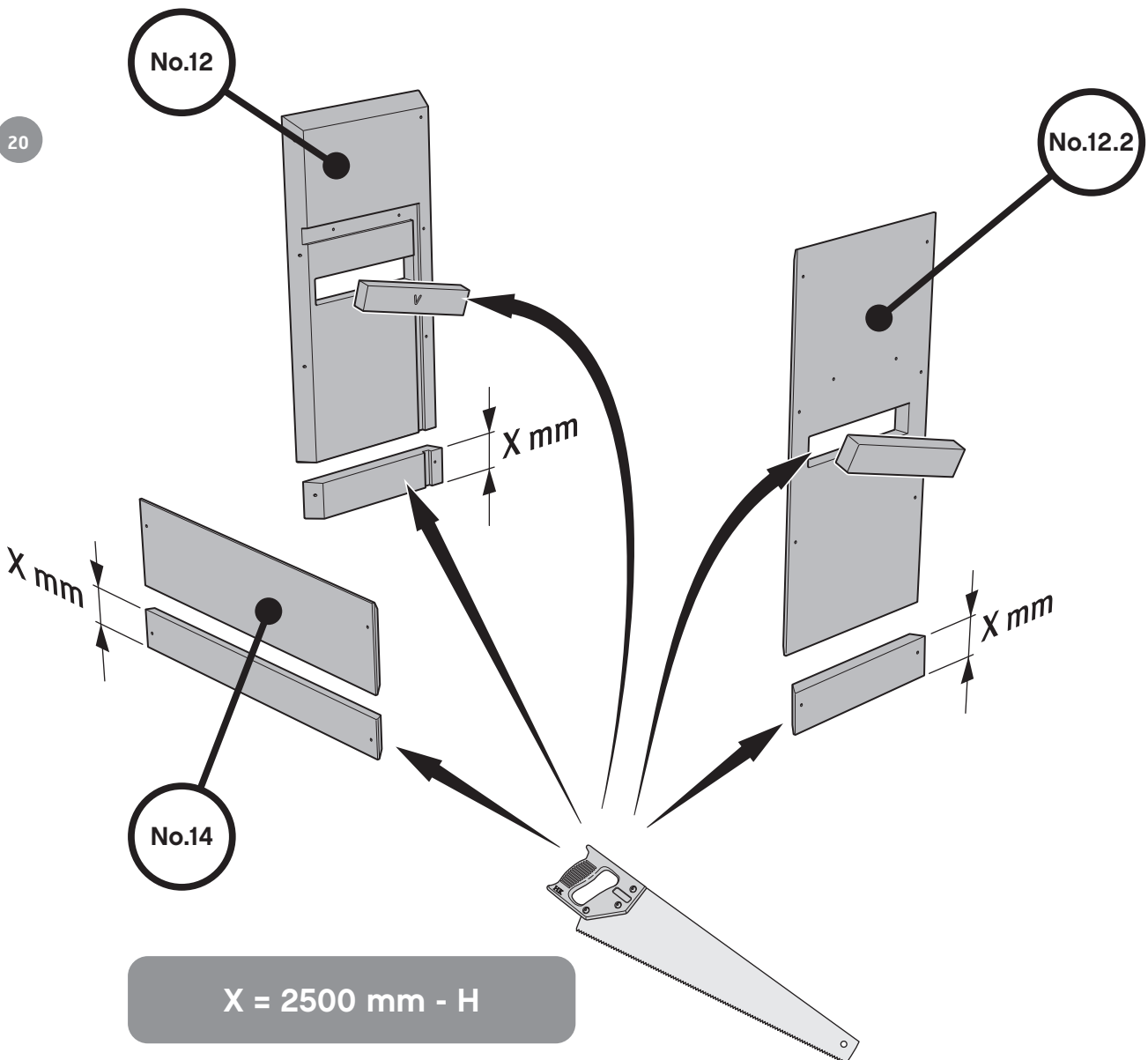

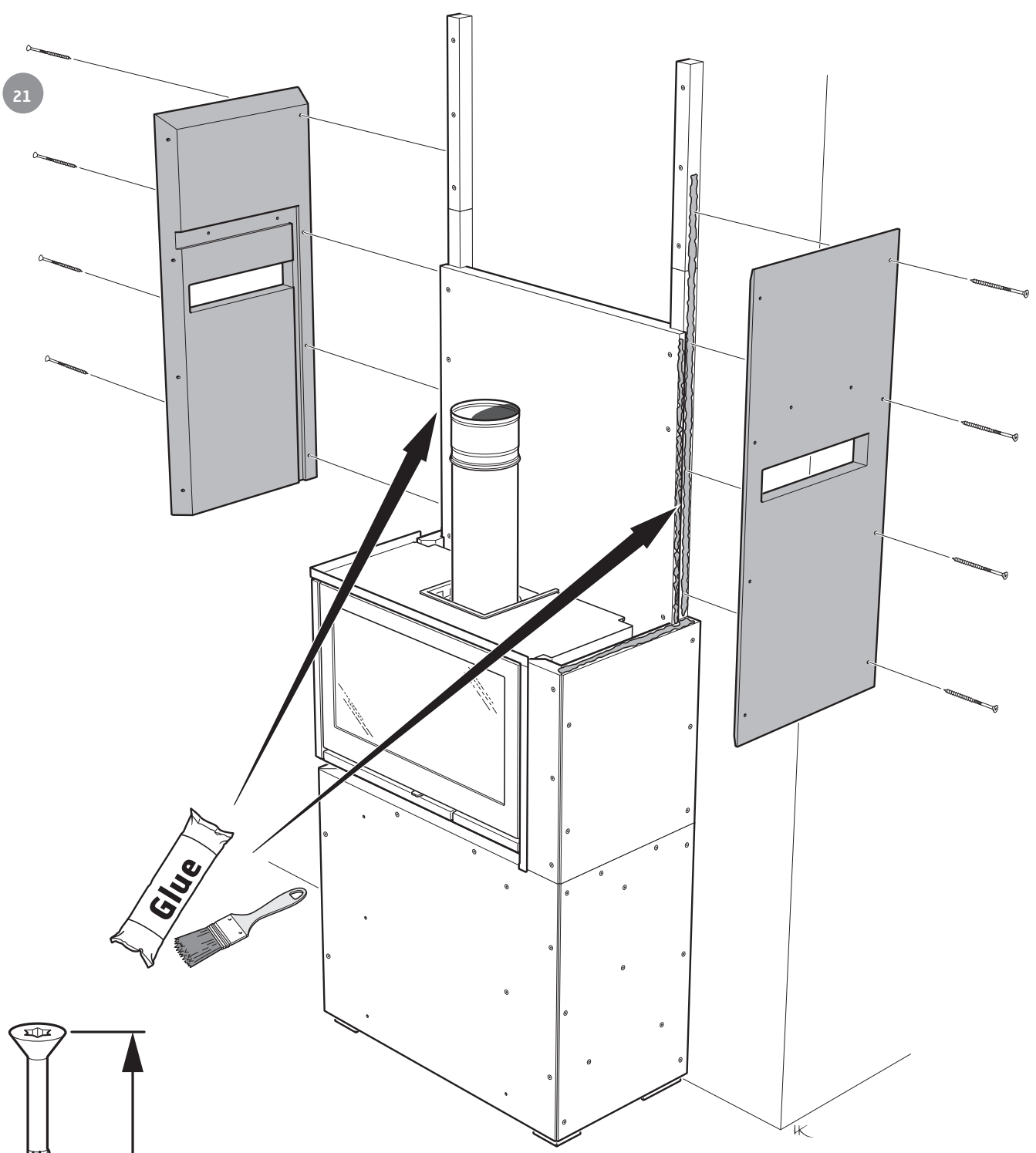





22

No.11

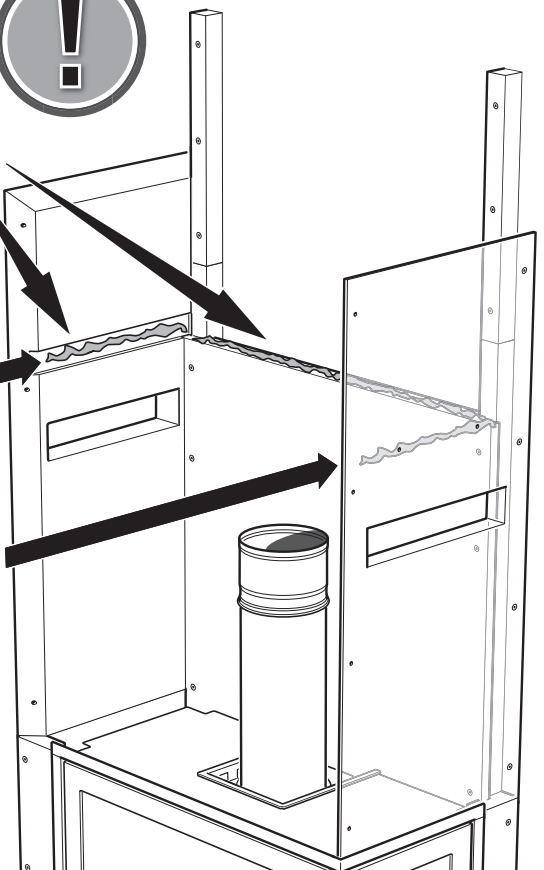
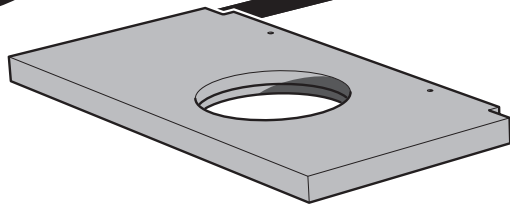
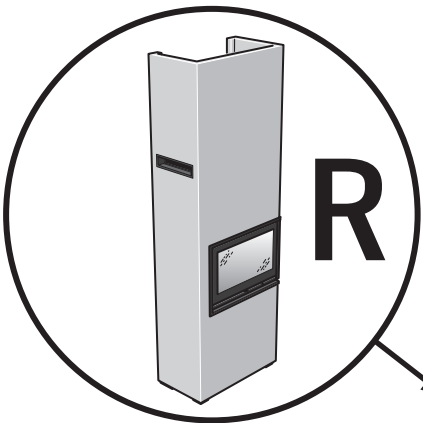
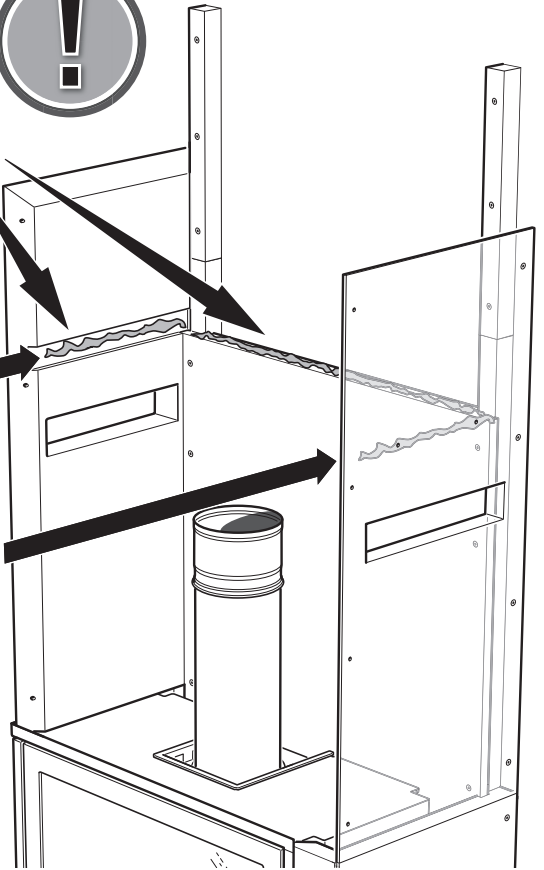
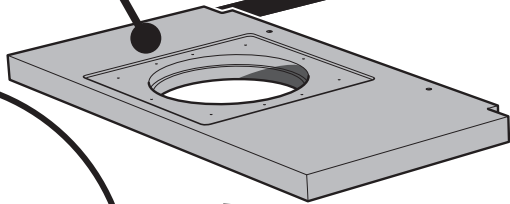
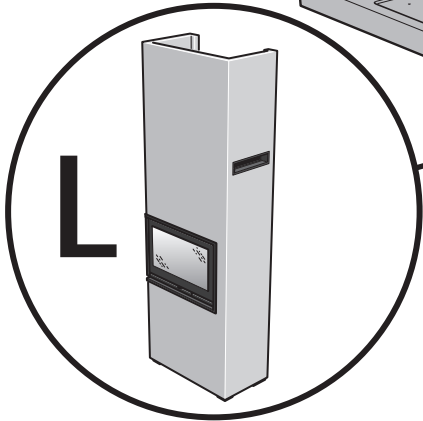



23

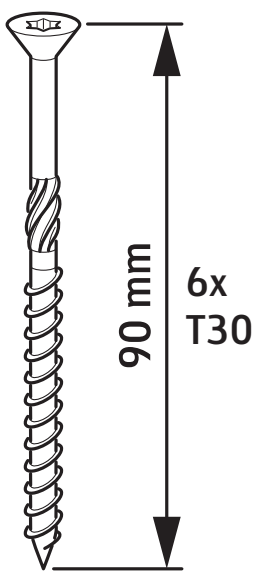
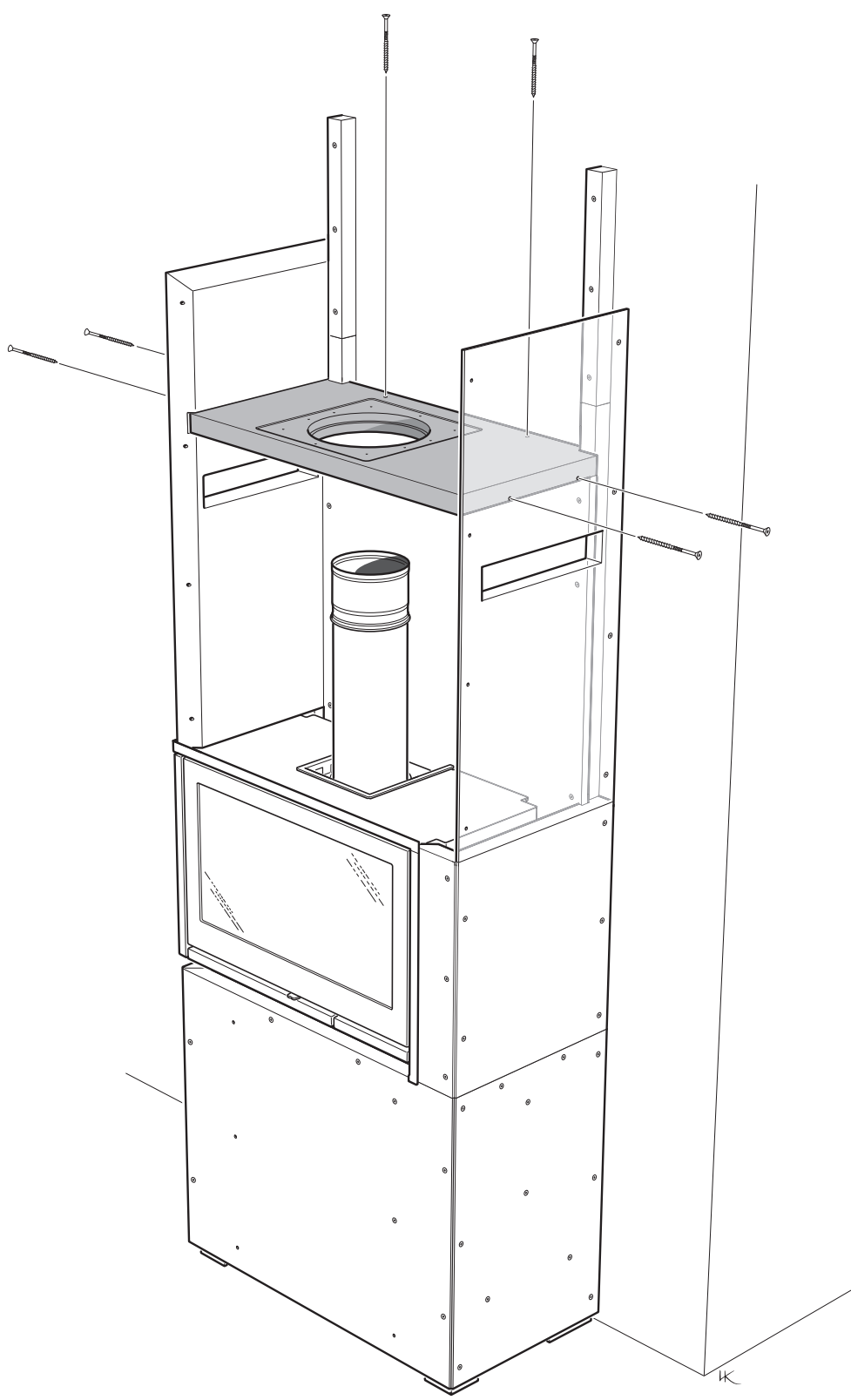



24

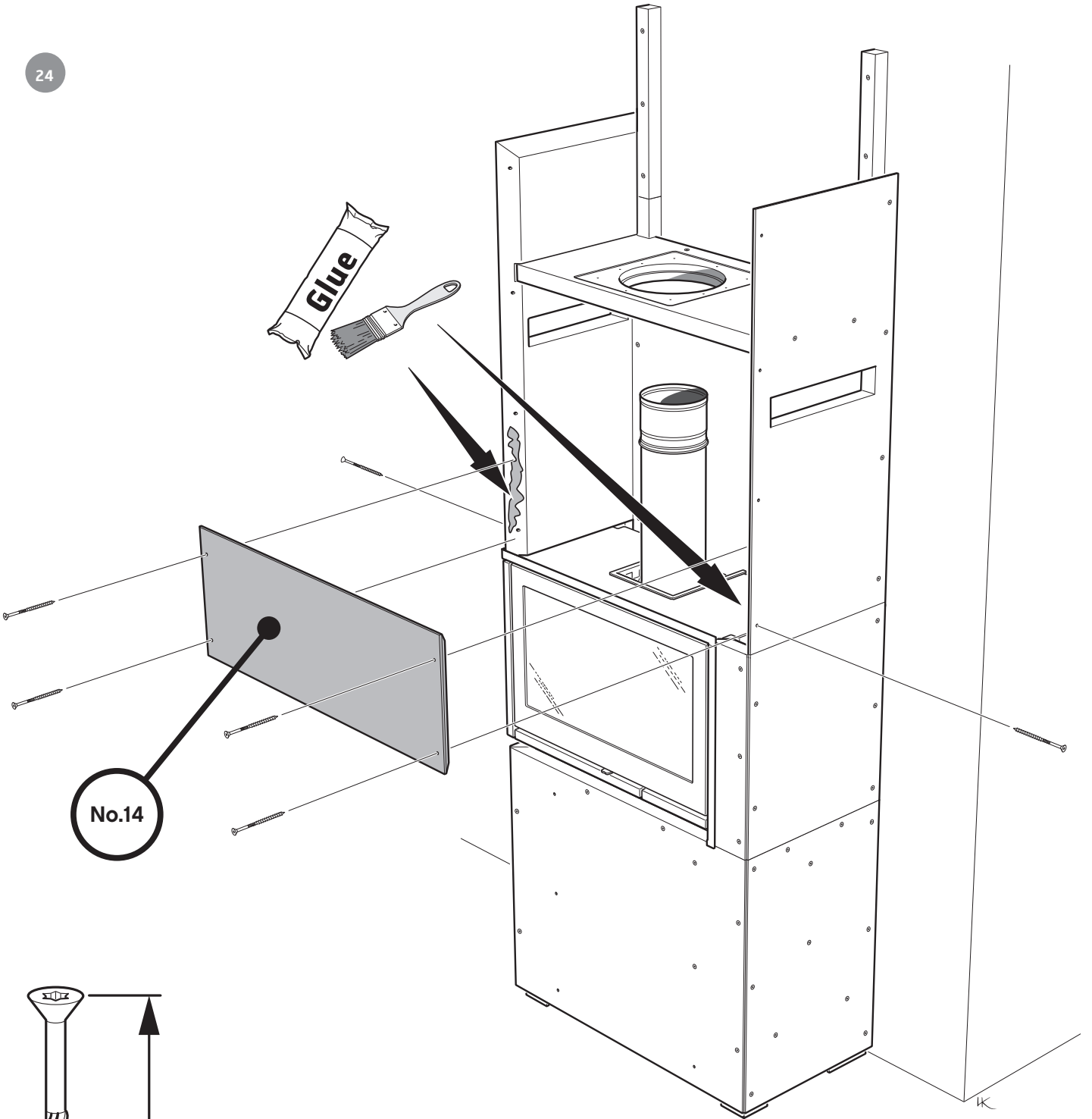

No.14

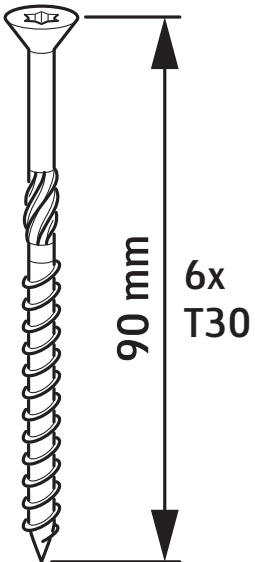

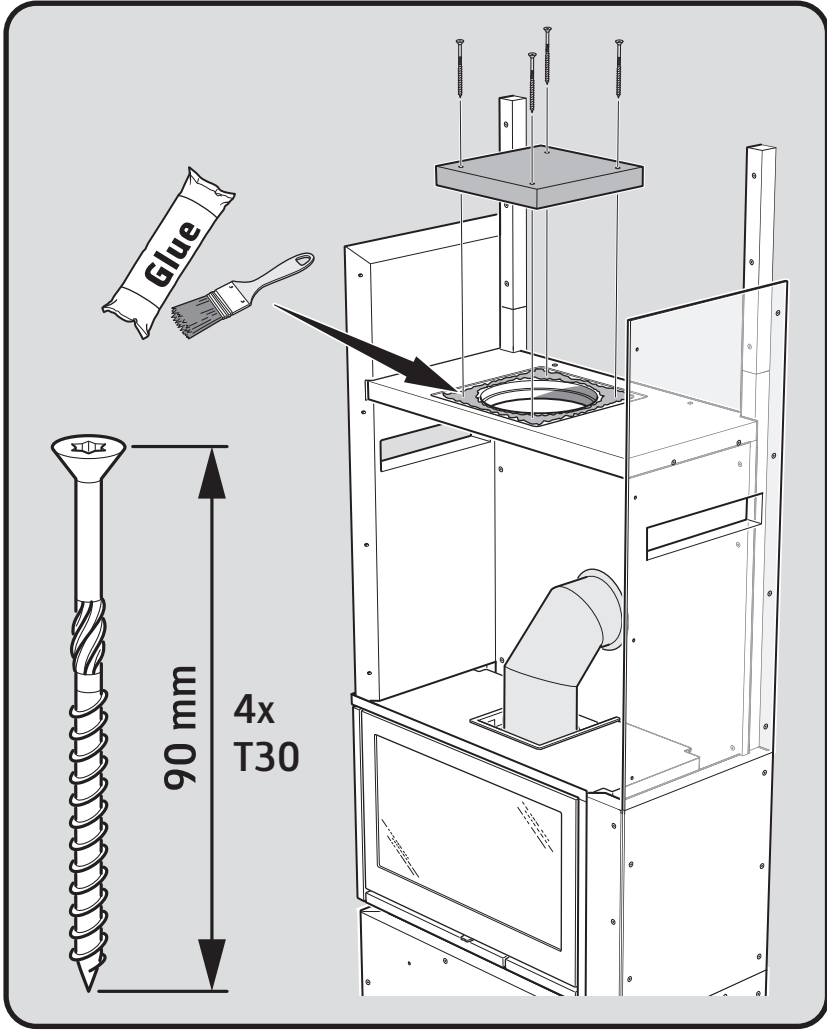

25

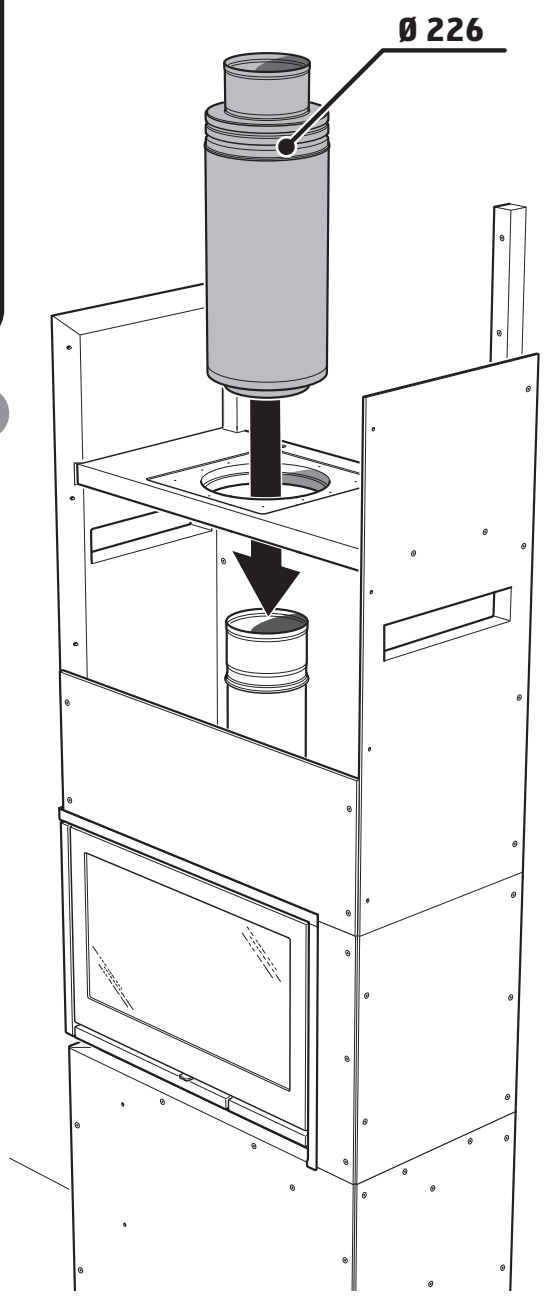



26

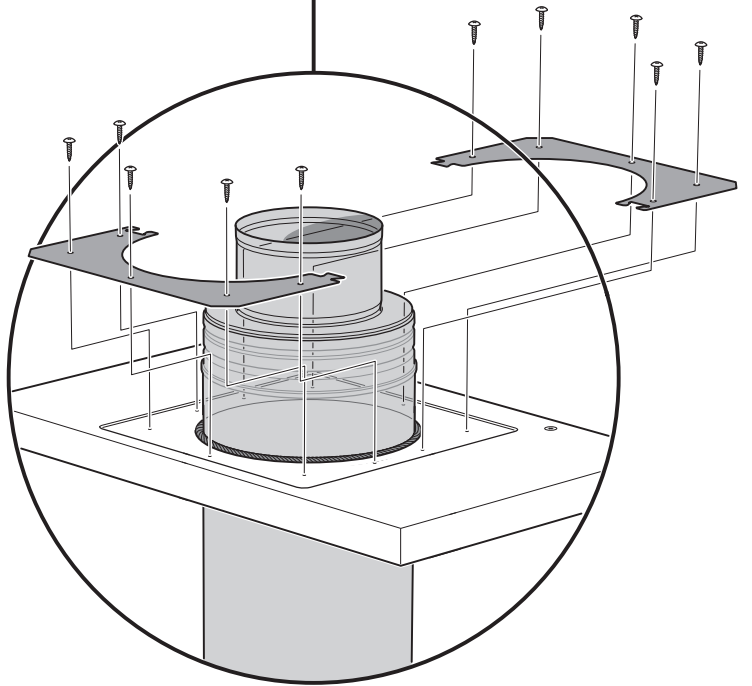
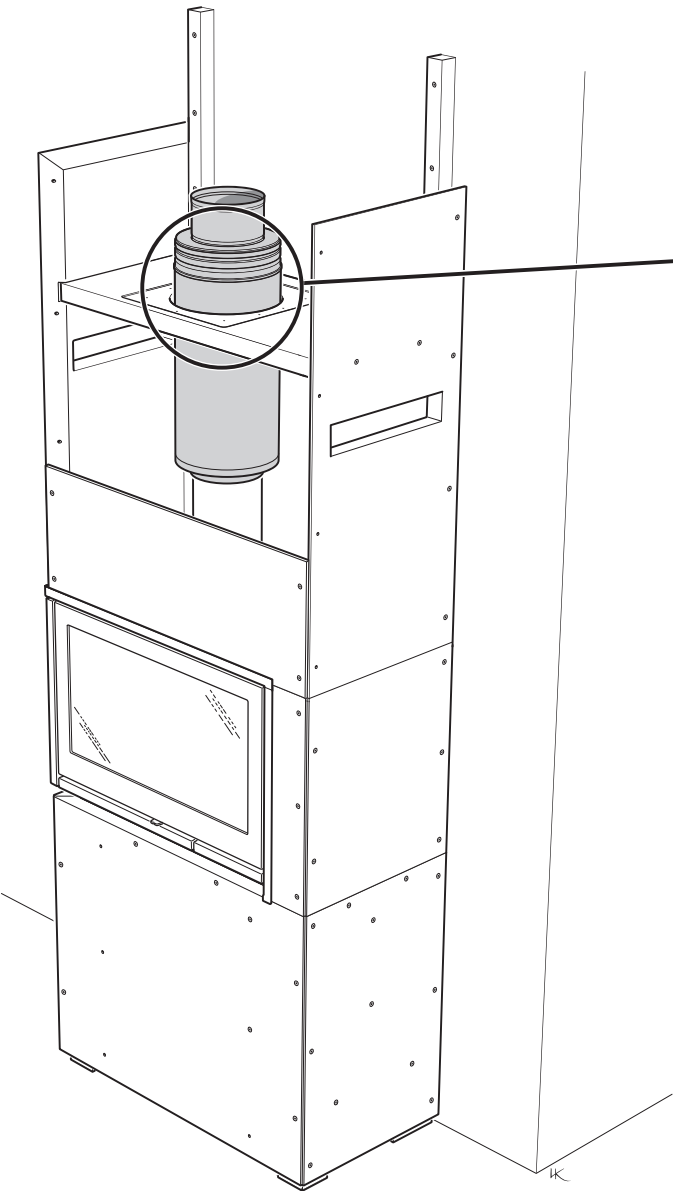
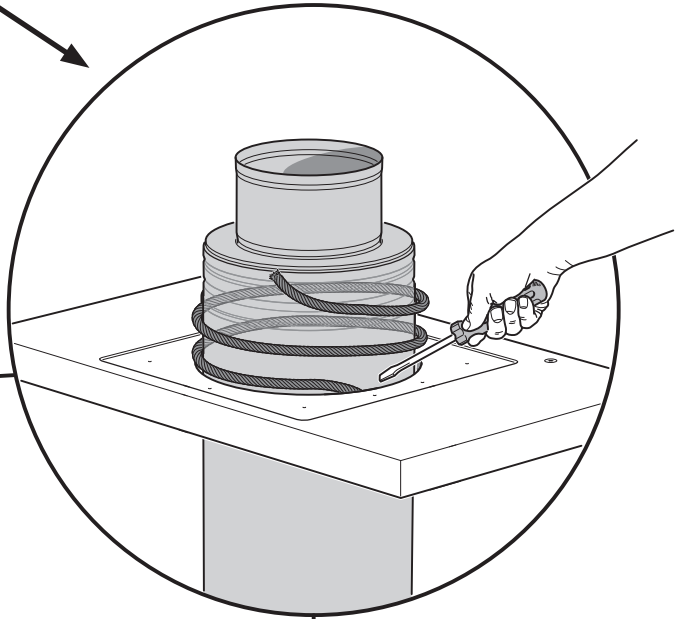
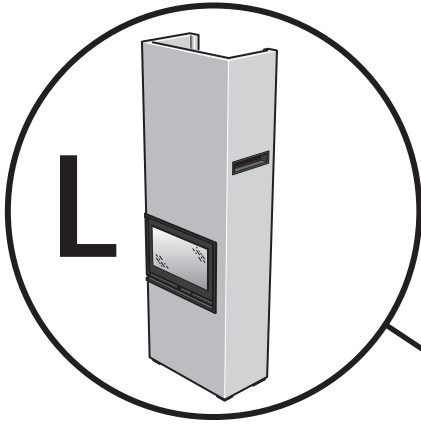



26

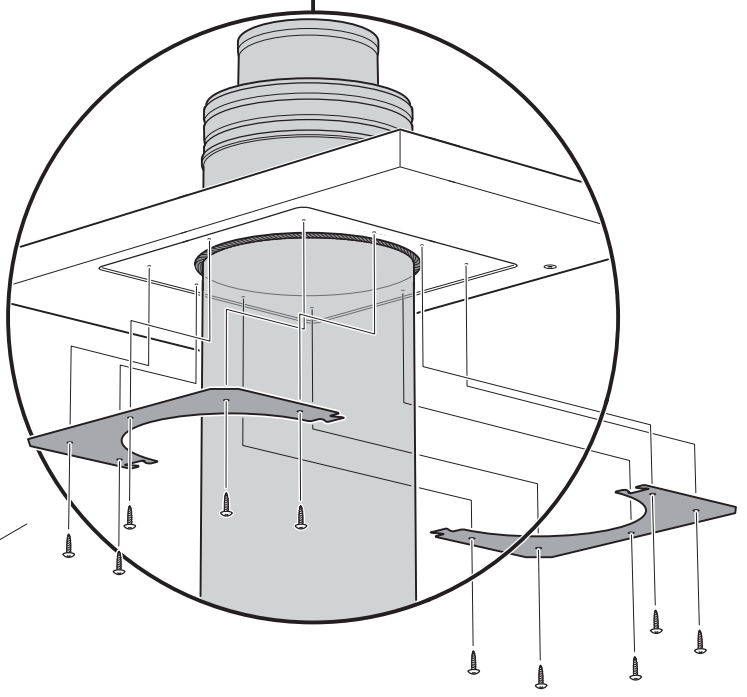
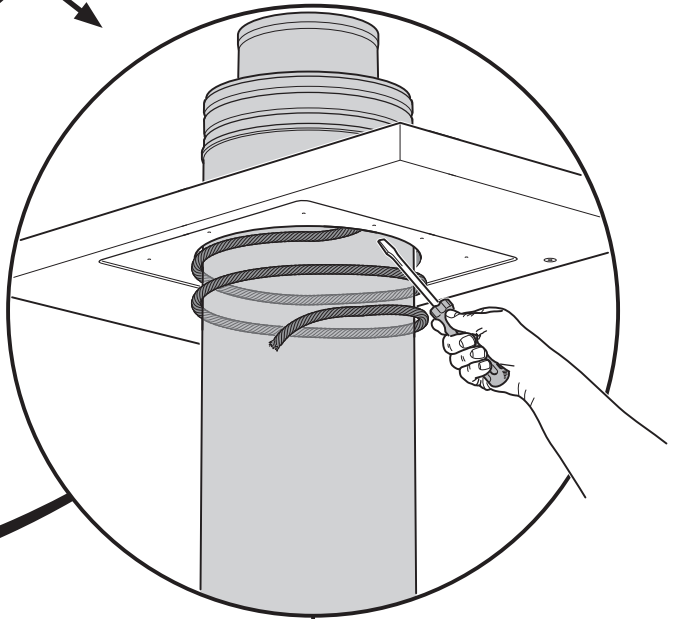
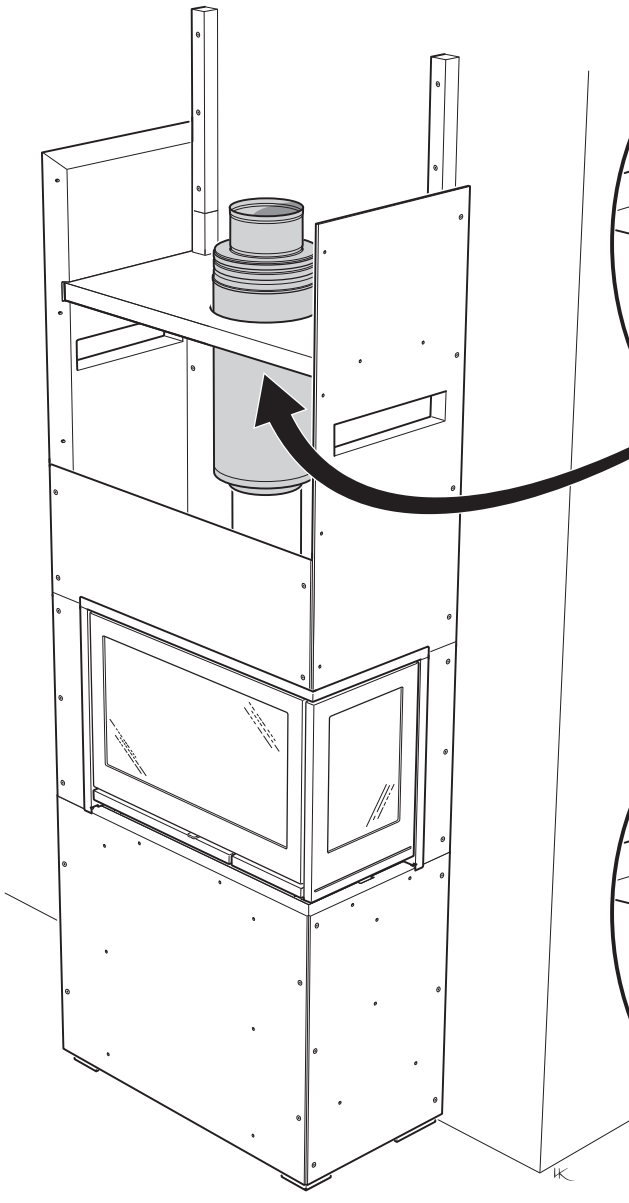
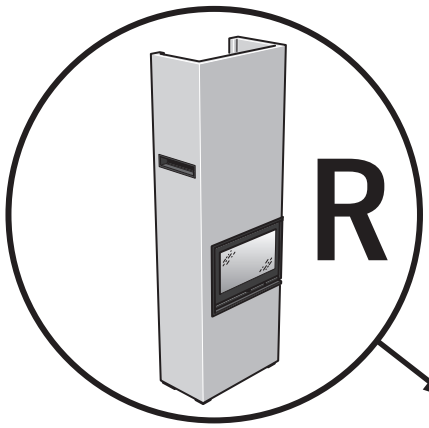

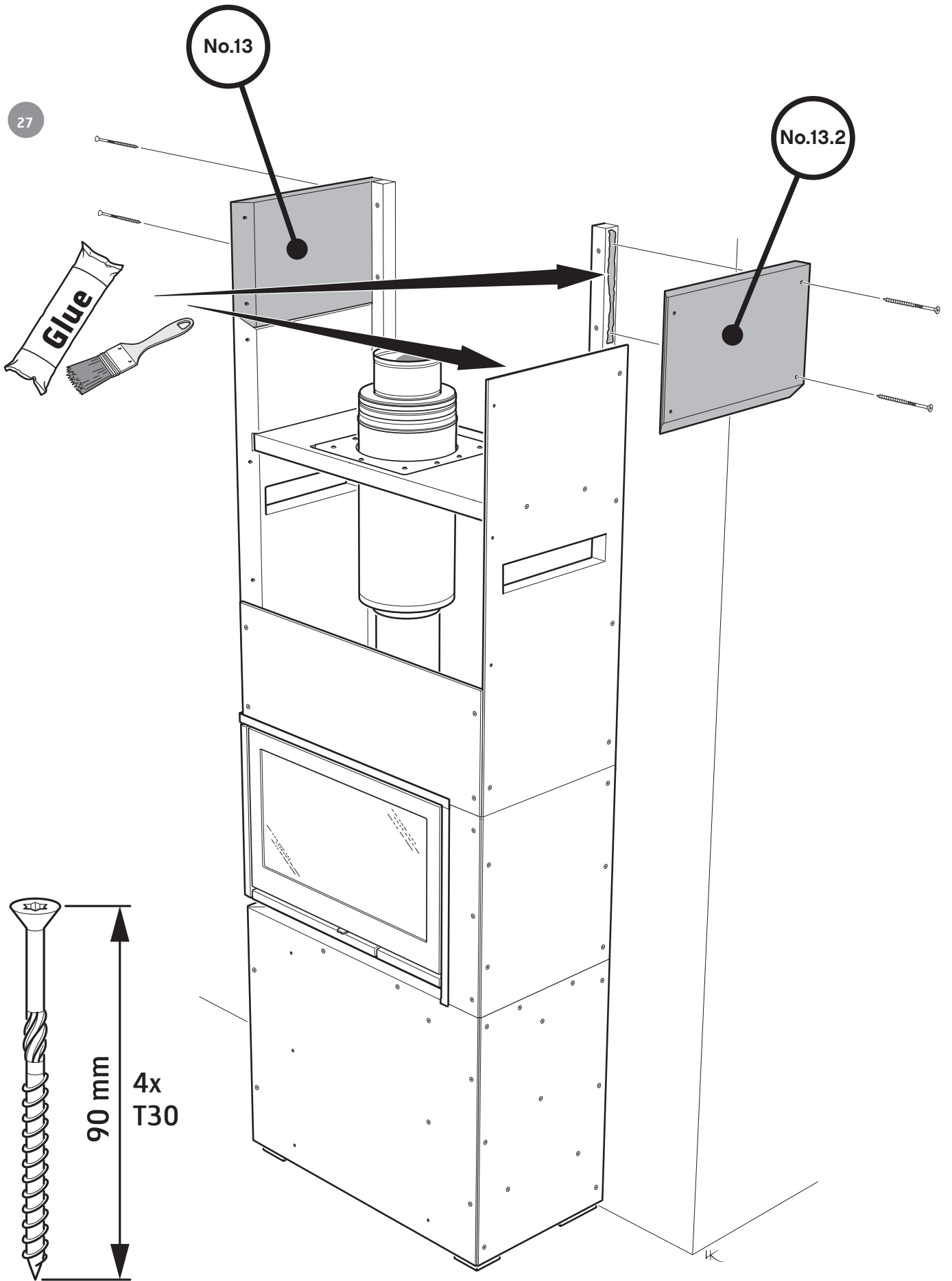

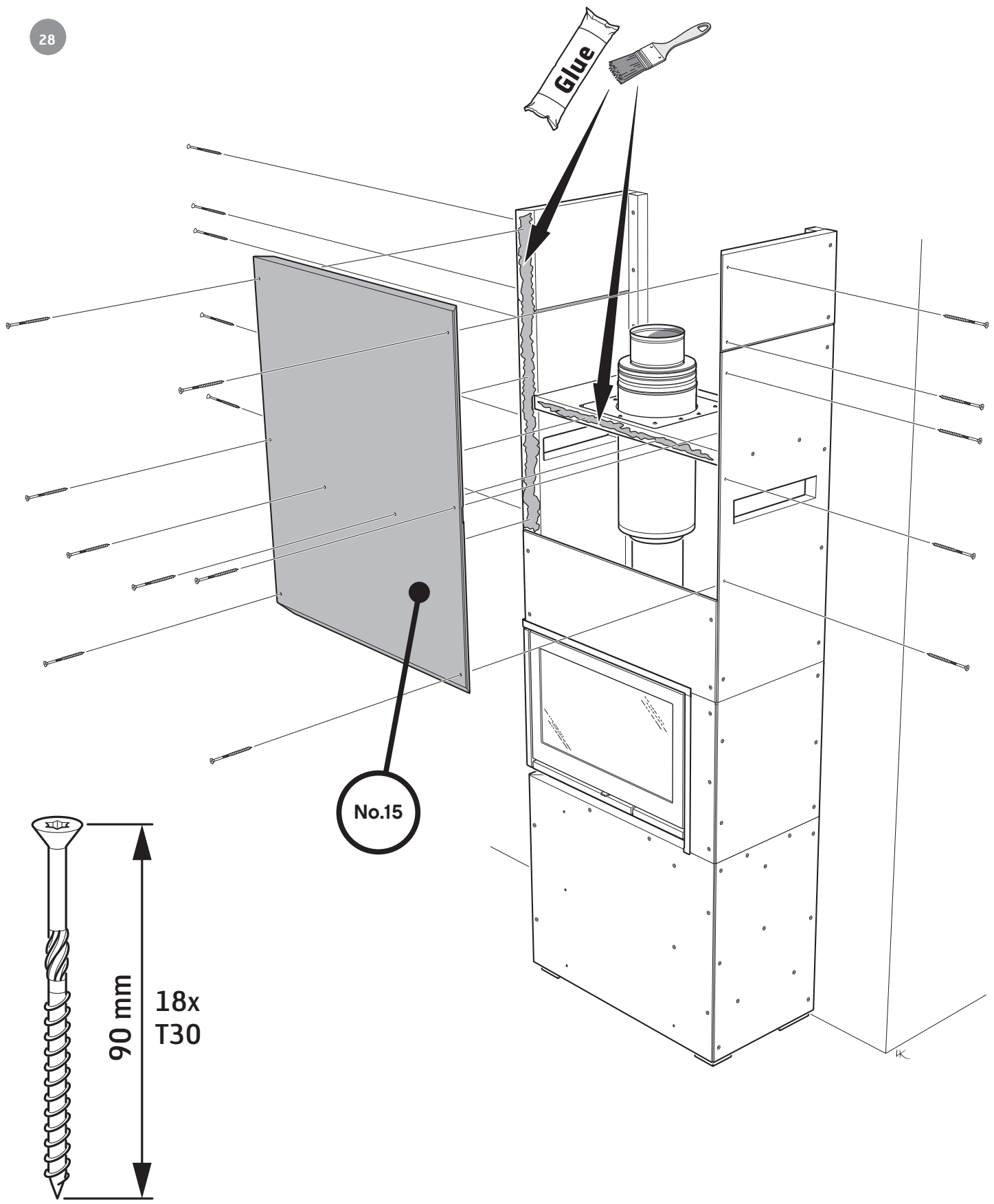



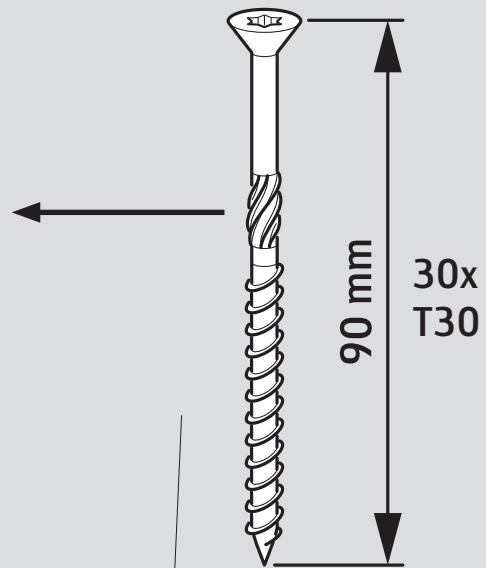
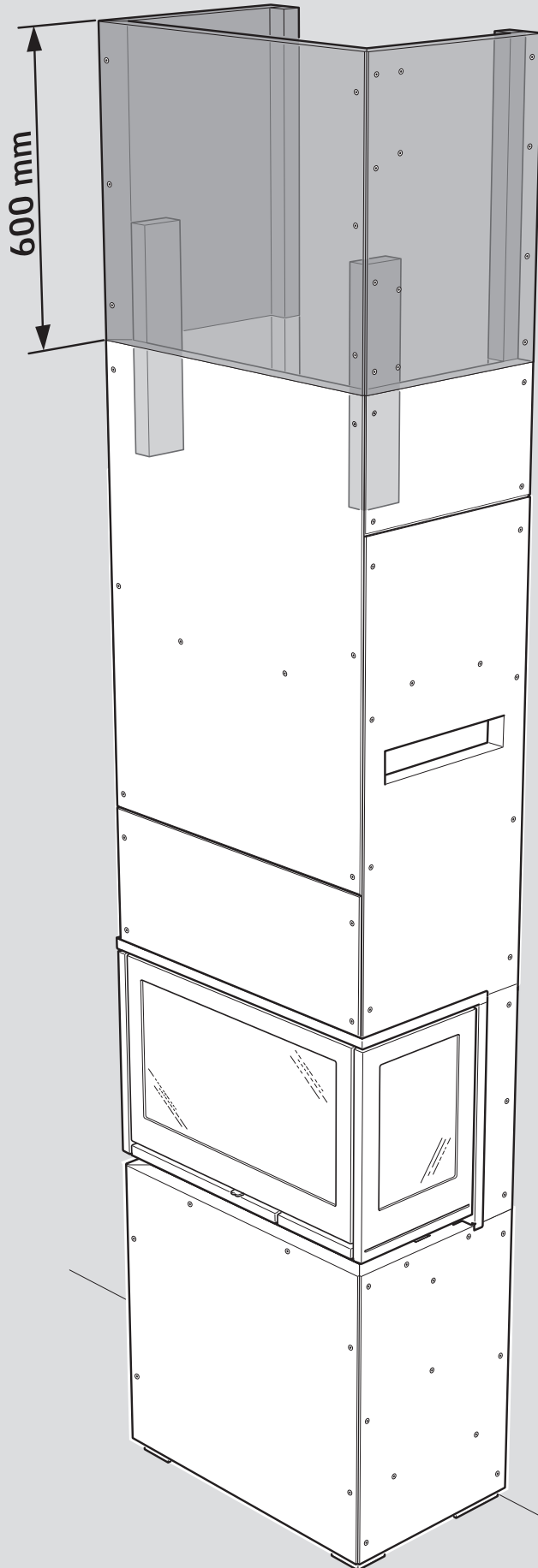

- SE Tillval
- DE Sonderzubehör
- NO Tilbehør
- FR Option
- GB Option
- DK Ekstraudstyr
- FI Lisävaruste
- IT Optional
- NL Optie



29

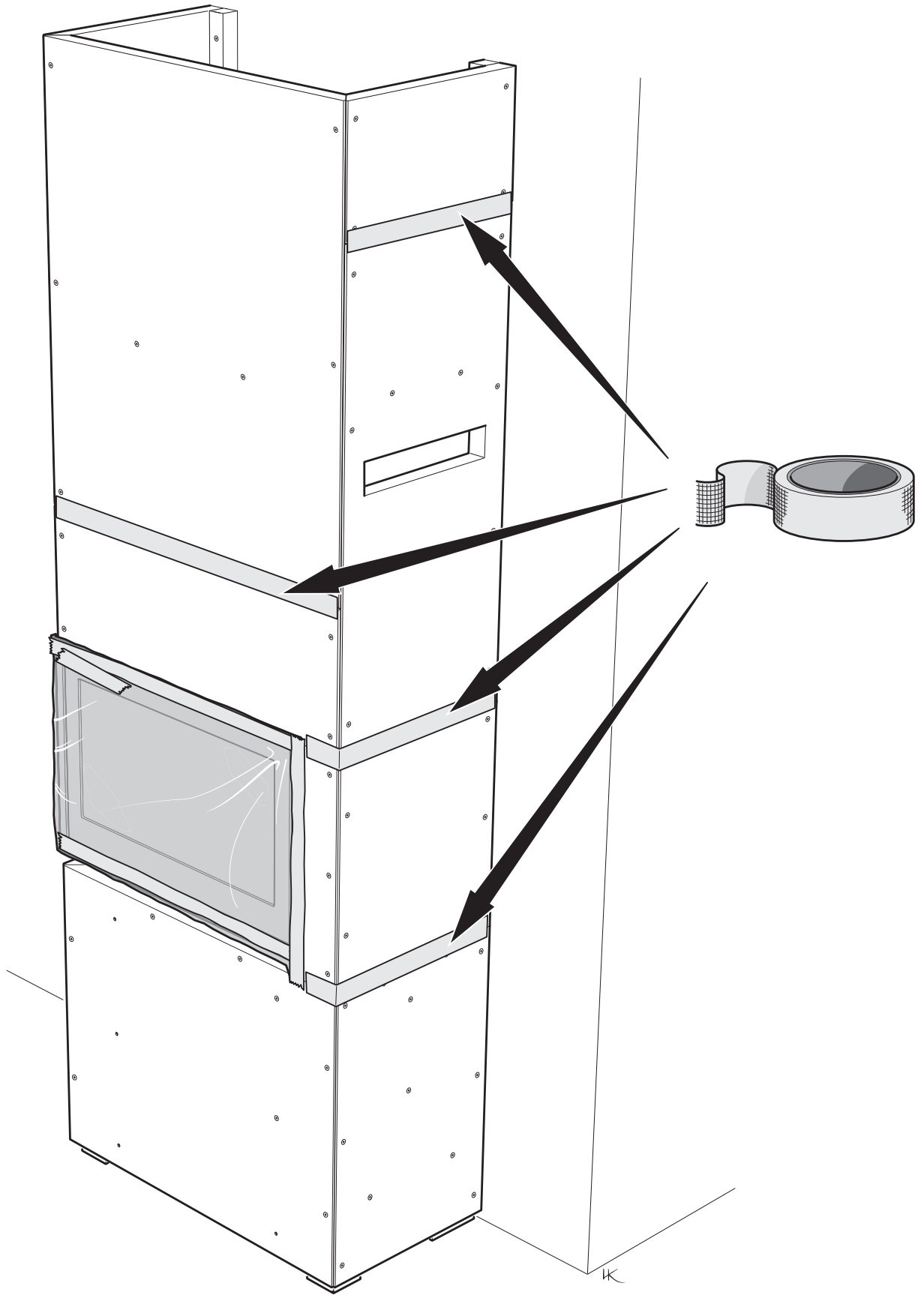



30

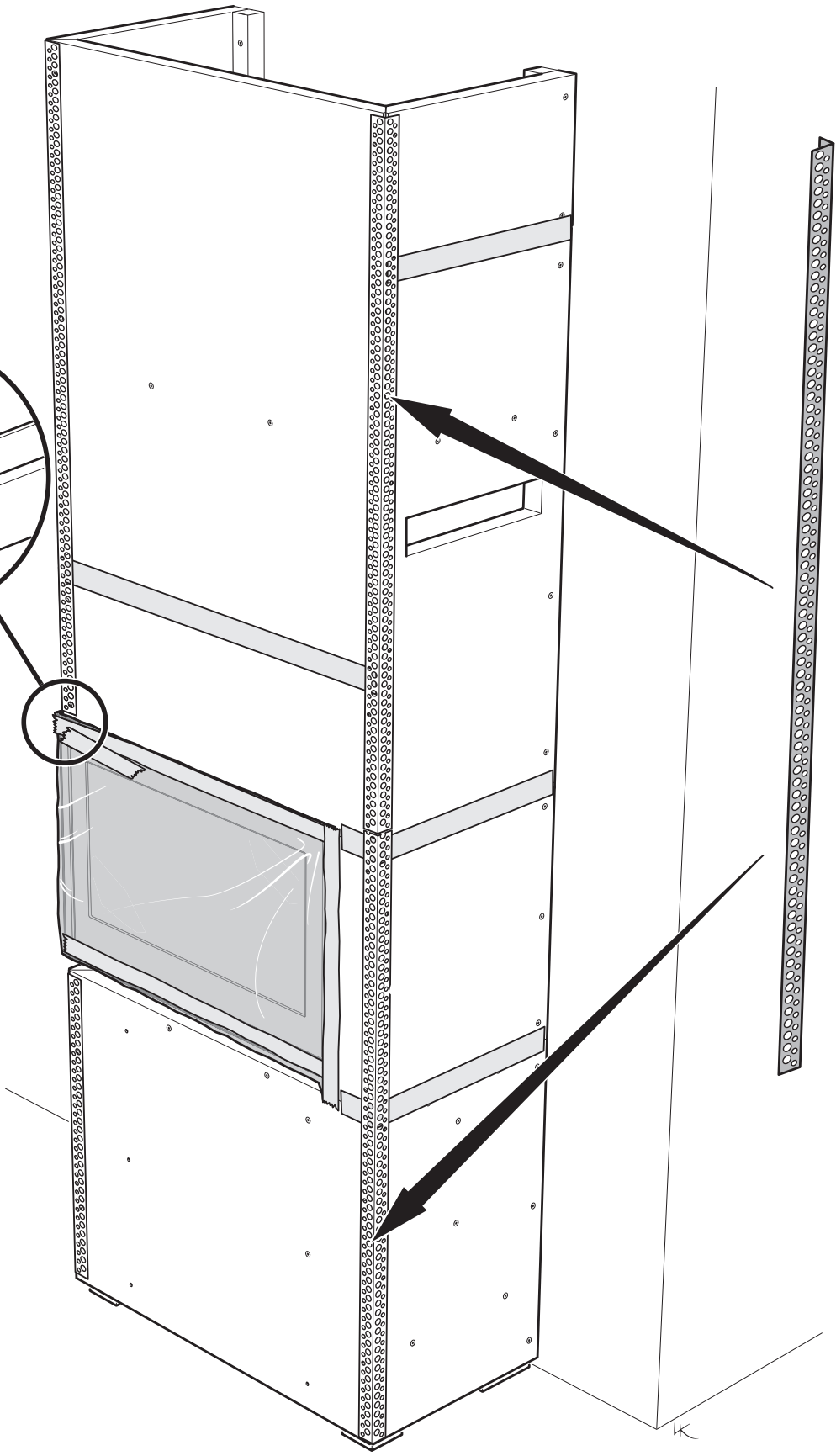
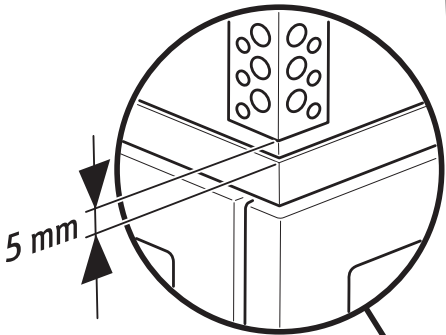

K



- SE** Plattorna är förbehandlade med en primer och kräver därför ingen ytterligare ytbehandling före spackling.
- DK** Pladerne er forbehandlet med en primer og kræver derfor ingen yderligere overfladebehandling før spartling.
- DE** Die Platten wurden mit einem Primer vorbehandelt und bedürfen deswegen vor dem Spachteln keiner weiteren Oberflächenbehandlung.
- FI** Levyt on esikäsitelty pohjamaalilla, joten ne eivät vaadi mitään ylimääräistä pintakäsittelyä ennen kittäystä.
- NO** Platene er forbehandlet med en primer og krever derfor ingen ytterligere overflatebehandling før sparkling.
- IT** Le piastre sono pre-trattate con un primer, quindi non è necessario alcun trattamento prima di stuccare.
- FR** Les panneaux sont revêtus d'un apprêt et n'exigent donc aucun traitement de surface supplémentaire avant l'application de mastic.
- NL** De platen zijn voorbehandeld met een primer en hebben daardoor vóór het plamuren geen verdere behandeling nodig.
- GB** The boards are pre-primed and therefore ready to be plastered without any other preparation.

31

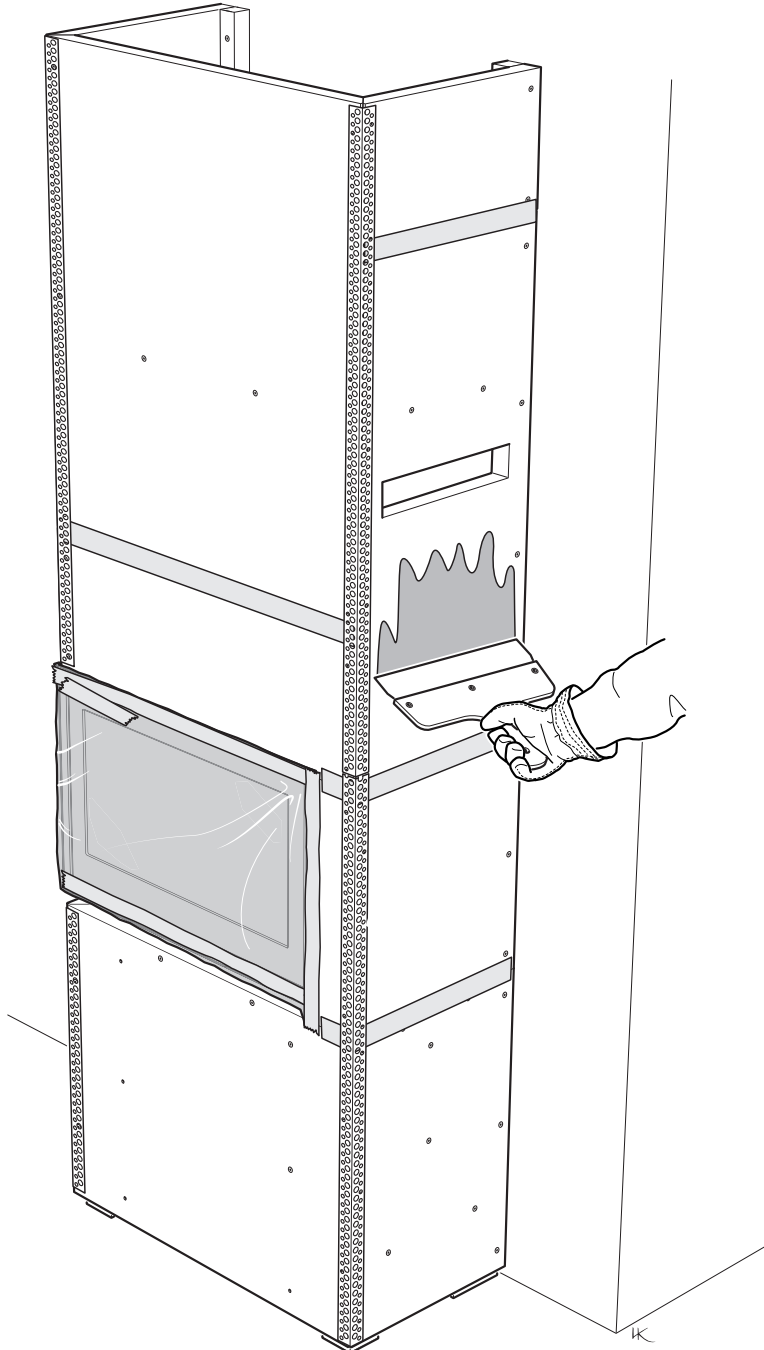



32

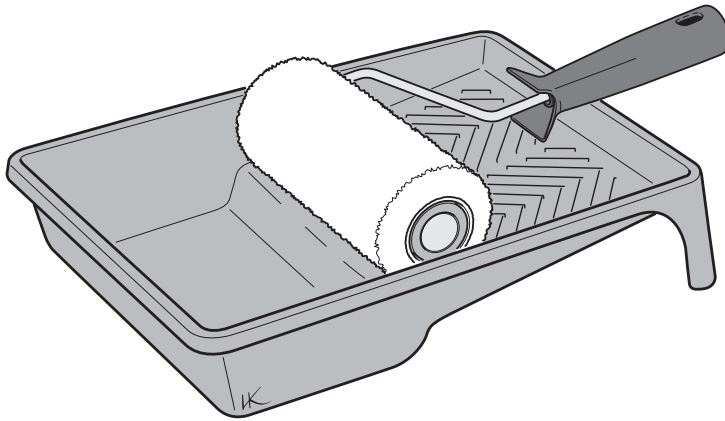

SE

### Lackering

När eldstaden spacklats och slipats med sandpapper kan du måla eldstaden. Använd diffusionsöppen färg (akryl) som är avsedd för murverk.

DE

### Lackieren

Der Kaminofen kann nach Fertigstellung der Spachtel- und Schleifarbeiten lackiert werden. Verwenden Sie diffusionsoffene Farbe (Acryl) für Mauerwerk.

NO

### Lakkering

Når ildstedet er sparklet og slipt med sandpapir, kan du male det. Bruk diffusionsåpen maling (akryl) som er beregnet for murverk.

FR

### Peinture

L'habillage de l'insert peut être peint après avoir appliqué les joints mastic et poncé les surfaces avec du papier de verre. Utiliser de la peinture perméable à la diffusion de vapeur d'eau (acrylique) destinée à la maçonnerie.

GB

### Painting

When the fireplace has been filled and sanded down with sandpaper, it is ready to be painted. Use a diffusion-open paint (acrylic) that is formulated for use on masonry.

DK

### Maling

Når ildstedet er spartlet og slebet med sandpapir, kan du male det. Benyt diffusionsåben farve (akryl), som er beregnet til murværk.

FI

### Maalaus

Takan voi maalata kittauksen ja hionnan jälkeen. Käytä tiilirakenteille tarkoitettua diffuusioavointa (akryyli)maalaa.

IT

### Verniciatura

Quando l'inserto è stato stuccato e levigato con cartavetro, è possibile procedere alla verniciatura. Usare una vernice traspirante (acrilica) specifica per opere di muratura.

NL

### Aflakken

Als de haard is gevoegd en geschuurd kunt u deze schilderen. Gebruik een diffusie-open verf (acryl) die geschikt is voor de stenen wanden.

33

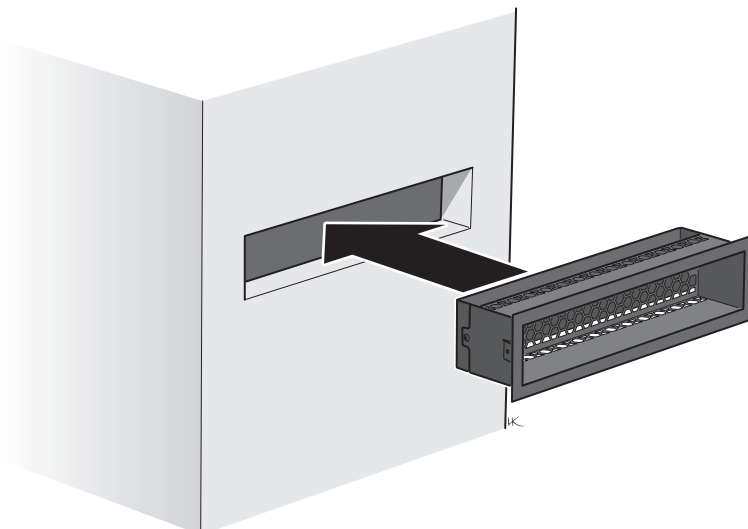



SE

Contura förbehåller sig rätten att ändra angivna mått och beskrivna förfaranden i denna anvisning utan särskilt meddelande. Den aktuella utgåvan kan laddas ner från [www.contura.eu](http://www.contura.eu)

DE

Contura behält sich das Recht vor, in diesem Dokument angegebene Abmessungen und beschriebene Vorgehensweisen ohne vorherige Ankündigung zu ändern. Die aktuelle Version dieser Heizinstruktion kann unter [www.contura.eu](http://www.contura.eu) heruntergeladen werden.

NO

Contura forbeholder seg retten til å endre angitte mål og beskrevet fremgangsmåte i denne anvisningen uten særskilt varsel. Den aktuelle utgaven kan lastes ned fra [www.contura.eu](http://www.contura.eu)

FR

Contura se réserve le droit de modifier sans notification préalable les mesures et les opérations décrites dans les présentes instructions. La dernière édition peut être téléchargée à partir de notre site [www.contura.eu](http://www.contura.eu)

GB

Contura reserves the right to change dimensions and procedures described in these instructions at any time without special notice. The current edition can be downloaded from [www.contura.eu](http://www.contura.eu)

DK

Contura forbeholder sig ret til at ændre de oplyste mål og beskrevne fremgangsmåder i denne vejledning uden særskilt varsel. Den aktuelle udgave kan downloades fra [www.contura.eu](http://www.contura.eu)

FI

Contura pidättää oikeudet tehdä muutoksia tässä ohjeessa annettuihin mittoihin ja menettelyohjeisiin ilman eri ilmoitusta. Uusimman version voi ladata osoitteesta [www.contura.eu](http://www.contura.eu)

IT

Contura si riserva il diritto di modificare senza preavviso le dimensioni indicate e le procedure descritte nelle presenti istruzioni. La versione più recente può essere scaricata da [www.contura.eu](http://www.contura.eu)

NL

Contura behoudt zich het recht voor zonder voorafgaande kennisgeving vermeldde maten en beschreven methoden te wijzigen. De actuele uitgave kan worden gedownload op [www.contura.eu](http://www.contura.eu)



